



Standard Practice for Ultrasonic Examination of Wrought Products^{1, 2}

This standard is issued under the fixed designation E 2375; the number immediately following the designation indicates the year of original adoption or, in the case of revision, the year of last revision. A number in parentheses indicates the year of last approval. A superscript epsilon (ϵ) indicates an editorial change since the last revision or reapproval.

1. Scope

1.1 *Purpose*—This practice establishes the minimum requirements for ultrasonic examination of wrought products.

NOTE 1—This standard was adopted to replace MIL-STD-2154, 30 Sept. 1982. This standard is intended to be used for the same applications as the document which it replaced. Users should carefully review its requirements when considering its use for new, or different applications, or both.

1.2 *Application*—This practice is applicable for examination of materials such as, wrought metals and wrought metal products.

1.2.1 *Wrought Aluminum Alloy Products*—Examination shall be in accordance with Practice B 594.

1.3 *Acceptance Class*—When examination is performed in accordance with this practice, engineering drawings, specifications, or other applicable documents shall indicate the acceptance criteria. Five ultrasonic acceptance classes are defined in Table 1. One or more of these classes may be used to establish the acceptance criteria or additional or alternate criteria may be specified.

1.4 *Order of Precedence*—Contractual requirements and authorized direction from the cognizant engineering organization may add to or modify the requirements of this practice. Otherwise, in the event of conflict between the text of this practice and the references cited herein, the text of this practice takes precedence. Nothing in this practice, however, supersedes applicable laws and regulations unless a specific exemption has been obtained.

1.5 *Measurement Values*—The values stated in inch-pounds are to be regarded as standard. The metric equivalents are in brackets.

1.6 *This standard does not purport to address all of the safety concerns, if any, associated with its use. It is the responsibility of the user of this standard to establish appropriate*

safety and health practices and determine the applicability of regulatory limitations prior to use.

2. Referenced Documents

2.1 The following documents form a part of this practice to the extent specified herein:

2.2 *ASTM Standards*:³

- B 107 Specification for Magnesium-Alloy Extruded Bars, Rods, Shapes, Tubes, and Wire
- B 221 Specification for Aluminum and Aluminum-Alloy Extruded Bars, Rods, Wire, Profiles, and Tubes
- B 241 Specification for Aluminum and Aluminum-Alloy Seamless Pipe and Seamless Extruded Tube
- B 594 Practice for Ultrasonic Inspection of Aluminum-Alloy Wrought Products for Aerospace Applications
- E 127 Practice for Fabricating and Checking Aluminum Alloy Ultrasonic Standard Reference Blocks
- E 164 Practice for Ultrasonic Contact Examination of Weldments
- E 213 Practice for Ultrasonic Examination of Metal Pipes and Tubing
- E 317 Practice for Evaluating Performance Characteristics of Ultrasonic Pulse-Echo Examination Instruments and Systems Without the Use of Electronic Measurement Instruments
- E 428 Practice for Fabrication and Control of Steel Reference Blocks Used in Ultrasonic Examination
- E 543 Practice for Agencies Performing Nondestructive Testing
- E 1065 Guide for Evaluating Characteristics of Ultrasonic Search Units
- E 1158 Guide for Material Selection and Fabrication of Reference Blocks for the Pulsed Longitudinal Wave Ultrasonic Examination of Metal and Metal Alloy Production Material
- E 1316 Terminology for Nondestructive Examinations

¹ This practice is under the jurisdiction of ASTM Committee E07 on Nondestructive Testing and is the direct responsibility of Subcommittee E07.06 on Ultrasonic Testing Procedures.

Current edition approved July 1, 2004. Published July 2004.

² When accepted by DoD this standard is expected to replace MIL-STD-2154.

³ For referenced ASTM standards, visit the ASTM website, www.astm.org, or contact ASTM Customer Service at service@astm.org. For *Annual Book of ASTM Standards* volume information, refer to the standard's Document Summary page on the ASTM website.

TABLE 1 Ultrasonic Classes

Class	Single Discontinuity Response ^{A,B}	Multiple ^C Discontinuities	Linear ^D Discontinuity Length and Response	Loss of Back Reflection Percent ^{E,F}	Noise ^{G,H}
AAA ^H	$\frac{3}{64}$ in. [0.794 mm] FB	$\frac{1}{64}$ in. [0.397 mm] FB	$\frac{1}{8}$ in. [3.175 mm] long $\frac{1}{64}$ in. response [0.397 mm] FB	50	alarm level
AA ^H	$\frac{3}{64}$ in. [1.19 mm] FB	$\frac{3}{64}$ in. ^I [0.794 mm] FB	$\frac{1}{2}$ in. [12.7 mm] long $\frac{3}{64}$ in. response [0.794 mm] FB	50	alarm level
A	$\frac{5}{64}$ in. [1.98 mm] FB	$\frac{3}{64}$ in. [1.191 mm] FB	1 in. [25.4 mm] long $\frac{3}{64}$ in. response [1.19 mm] FB	50	alarm level
B	$\frac{5}{64}$ in. [3.18 mm] FB	$\frac{5}{64}$ [1.98 mm] FB	1 in. [25.4 mm] long $\frac{5}{64}$ in. response [1.98 mm] FB	50	alarm level
C	$\frac{5}{64}$ in. [3.18 mm]	Not Applicable	Not Applicable	50	alarm level

^A Any discontinuity with a response greater than the response from a flat-bottom hole or equivalent notch (see footnote^B) at the estimated discontinuity depth and the discontinuity size given is not acceptable.

^B See Fig. 3, Fig. 4, or Fig. 5 for dimensions of notches and holes when these are required for angle beam examination of tube walls and near-surface regions of cylindrical parts and other products.

^C Multiple discontinuities with indications greater than the response from a reference flat-bottom hole or equivalent notch at the estimated discontinuity depth of the size given (diameter) are not acceptable if the centers of any two of these discontinuities are less than one inch apart (not applicable to Class C).

^D Any discontinuity longer than the length given with indications equal to or greater than the response given (flat-bottom hole or notch response) is not acceptable. Not applicable to Class C).

^E Loss of back reflection by more than 50 %, when compared to non-defective material in the same or a similar part, is not acceptable.

^F For longitudinal examination of material over 6-in. [152.4-mm] thick in the short transverse direction, any loss of back reflection equal to or greater than 12 dB over an area 2 by 2 in. [50.8 by 50.8 mm] is rejectable. (Noise level is not relevant to this back reflection evaluation.)

^G Noise which exceeds the alarm level setting (see 7.4.10.7), is not acceptable, except for titanium. For titanium alloys, the alarm level may be set just above the noise level, but shall not exceed 70 % of the reference standard response.

^H When examining titanium, Class AA and Class AAA, no rejection shall be made on the basis of "noise" level, if within the limits specified in footnote^G.

^I Evaluation may be done by setting up on a $\frac{3}{64}$ in. [1.19 mm] hole and adding 7 dB of gain. (Also see Note 5 under Table 5.)

2.3 American Society for Nondestructive Testing (ASNT) Standards:

SNT-TC-1A Recommended Practice for Personnel Qualification and Certification in Nondestructive Testing⁴

ANSI/ASNT-CP-189 ASNT Standard for Qualification and Certification of Nondestructive Testing Personnel⁴

2.4 Society for Automotive Engineers (SAE) Standards:

AMS 4928 Titanium Alloy, Bars, Wire, Forgings, and Rings 6Al-4V Annealed⁵

AMS 6409 Steel, Bars, Forgings, and Tubing, 0.80 Cr, 1.8 Ni, 0.25 Mo, (0.38 - 0.45 C), (SAE 4340) Special Aircraft Steel Cleanliness, Normalized and Tempered⁵

AMS 6415 Steel, Bars, Forgings, and Tubing, 0.80 Cr, 1.8 Ni, 0.25 Mo (0.38 - 0.43 C) (SAE 4340)⁵

AMS 6484 Steel, Bars, Forgings, and Tubing, 0.80 Cr, 1.8 Ni, 0.25 Mo (0.38 - 0.43 C) (SAE 4340) Normalized and Tempered⁵

2.5 Aerospace Industries Association Standard:

NAS 410 Certification and Qualification of Nondestructive Test Personnel⁶

2.6 Federal Specifications:

QQ-A-225/6 Aluminum Alloy Bar, Rod, and Wire, Rolled, Drawn, or Cold Finished, 2024⁶

QQ-A-225/9 Aluminum Alloy Bar, Rod, Wire, and Special Shapes, Rolled, Drawn, or Cold Finished, 7075⁶

2.7 Military Standards:⁷

NOTE 2—For DoD contracts, unless otherwise specified, the issues of the documents which are DoD adopted are those listed in the issue of the DoDISS (Department of Defense Index of Specifications Standards) cited in the solicitation.

3. Terminology

3.1 *Definitions*—Definitions relating to ultrasonic examination, which appear in Terminology E 1316, shall apply to the terms used in this standard.

3.2 Definitions of Terms Specific to This Standard:

3.2.1 *back surface resolution*—the minimum distance between the back surface and a discontinuity of known size that will result in a clear differentiation of the two signals as indicated by the trace recovering to 20 % or less of discontinuity or back surface amplitude (whichever is lower) between the indications at the sensitivity required for the specified examination.

3.2.2 *cognizant engineering organization*—the company, government agency, or other authority responsible for the design, or end use, of the system or component for which ultrasonic examination is required. This, in addition to design

⁴ Available from The American Society for Nondestructive Testing (ASNT), P.O. Box 28518, 1711 Arlinggate Ln., Columbus, OH 43228-0518.

⁵ Available from Society of Automotive Engineers (SAE), 400 Commonwealth Dr., Warrendale, PA 15096-0001.

⁶ Aerospace Industries Association of America, Inc., 1250 Eye Street NW, Washington, DC 20005.

⁷ Copies of specifications, standards, drawings and publications required by manufacturers in connection with specific acquisition functions should be obtained from the contracting activity or as directed by the contracting officer.

personnel, may include personnel from engineering, material and process engineering, stress analysis, NDT or quality groups and others, as appropriate.

3.2.3 *contract document*—any document specified in the contract, including the purchase order, specification, drawing, or other written material.

3.2.4 *display*—the display on which ultrasonic data are presented, including, but is not limited to, cathode ray tubes, liquid crystals, electro-luminescent phosphors, or plasmas.

3.2.5 *entry surface resolution*—the minimum distance between the entry surface and a discontinuity of known size that will result in a clear differentiation of the two signals as indicated by the trace recovering to 20 % or less of the discontinuity amplitude between the indications at the sensitivity required for the specified examination.

3.2.6 *full scale deflection (FSD)*—the maximum displayable signal amplitude on the display device, or any signal reaching or exceeding the 100 % amplitude scale graduation.

3.2.7 *horizontal limit*—the maximum readable length of horizontal position that is determined either by electrical or a physical limit in the A-scan presentation of an ultrasonic examination instrument.

3.2.8 *immersion ultrasonic examination*—the use of a water medium to couple the search unit to the part surface. This technique includes immersion in a tank of water, the use of water columns, bubblers, or similar device.

3.2.9 *primary reference response*—the maximized signal amplitude obtained from the applicable reference reflector that produces the lowest amplitude signal.

3.2.10 *vertical linearity limit (upper and lower)*—values of the vertical amplitude at which a proportional relationship with the input signal deviates from or exceeds a prescribed amount.

4. Significance and Use

4.1 This practice is intended primarily for the examination of wrought metals, forged, rolled, machined parts or components to an ultrasonic class most typically specified in the purchase order or other contract document.

5. Basis of Application

5.1 *Basis of Application*—There are areas in this practice that may require agreement between the cognizant engineering organization and the supplier, or specific direction from the cognizant engineering organization.

6. General Requirements

6.1 *Specifying*—When ultrasonic examination is specified in accordance with this practice, the ultrasonic technique (immersion, contact, angle beam, straight beam, and so forth) and acceptance criteria should be specified. Suggested classes in **Table 1** may be specified to establish acceptance criteria. A contract document shall specify zones, when applicable, to indicate different quality level acceptance criteria based on the criticality of each zone. When directions of maximum stressing are indicated on a contract document and configuration allows, ultrasonic examination shall be performed to locate discontinuities oriented perpendicular to the directions of maximum stressing.

6.2 *Personnel Qualification/Certification*—Personnel performing examinations to this practice shall be qualified in accordance with **ANSI/ASNT-CP-189**, **NAS-410**, or **SNT-TC-1A** and certified by the employer or certifying agency as applicable. Other equivalent qualification documents may be used when specified in the contract or purchase order.

6.3 *Agency Evaluation*—If required by contract, evaluation of the agency performing examination shall be in accordance with Practice **E 543**.

6.4 *Written Procedure*—A detailed procedure (general procedure, or part specific technique, or both) shall be prepared for each part and type of examination to be performed. The procedure shall meet the requirements of this practice and shall provide consistency for producing the results and quality level required by this practice and other contractual documents. The procedure shall be approved by an individual qualified and certified as a Level III in the practice of ultrasonic examination. The procedure shall be submitted upon request to the contracting agency for approval, or review, or both (see **8.1**). The procedure shall cover all of the specific information required to set-up and perform the examination, such as the following:

6.4.1 Name and address of examination facility,

6.4.2 Number of the procedure including latest revision designation, if applicable, and date.

6.4.3 Number of this standard including latest revision designation letter, if applicable, and date.

6.4.4 Examination method and acceptance criteria to be applied.

6.4.5 Examination zones, if applicable.

6.4.6 Specific part number and configuration or product form for which the procedure is being prepared.

6.4.7 Manufacturer and model numbers of any instrumentation to be used in the examination. Any external recording equipment, alarm equipment and electronic distance-amplitude correction equipment shall be included.

6.4.8 Type and size of search unit. Include frequency, focal length, as applicable, manufacturer, sound beam angle and description of any wedges, shoes, saddles, stand-off attachments, bubblers, or squirters.

6.4.9 Description of manipulating and scanning equipment.

6.4.10 Couplant: type and manufacturer.

6.4.11 Scanning plan which describes, for each portion of the examination, the surfaces from which the examination will be performed, the ultrasonic modes, and directions of the sound beam.

6.4.12 Method of applying transfer (see **7.4.10.4**), if applied.

6.4.13 Reference blocks, water path (if applicable) and methods of standardization and scan index determination, maximum scanning speed, and minimum pulse repetition rate.

6.4.14 Method of establishing scan sensitivity for concave and convex surfaces, if applicable.

6.4.15 Discontinuity evaluation procedure.

6.4.16 Any other pertinent data which would be needed to duplicate the original examination.

6.5 *General Procedures*—General procedures are acceptable for common product forms such as plate, bar stock,

extrusions, forgings, tubing and cylindrical stock, and designated thickness ranges. The general procedure shall include the applicable items of 6.4.

7. Detail Requirements

7.1 Couplants:

7.1.1 *Immersion Method*—For the immersion method (see 7.2.8), water shall be free of air bubbles and other foreign material that could interfere with ultrasonic examinations. A suitable corrosion inhibiting agent, or a wetting agent, or both, shall be added to the water, if necessary. The specific inhibiting and wetting agents including mixing concentrations shall have been previously determined to be compatible with the materials to be examined.

7.1.2 *Contact Method*—For the contact method, a liquid or semi-liquid that forms a thin film between the search unit and the part is required. The couplant material used shall not be injurious to the material to be examined and will permit detection of applicable discontinuity sizes. Glycerin (Pure), silicones and graphite greases shall not be used as couplants, unless specifically permitted by the cognizant engineering organization.

7.2 Equipment:

7.2.1 *Electronic Equipment*—The equipment when used with appropriate search units shall be capable of producing ultrasonic examination frequencies as required by the application. The electronic equipment shall be calibrated after any repair or part/component replacement which could affect its response characteristics, or once each year, whichever occurs first. Records of the current calibration shall be retained and available for review.

7.2.1.1 The equipment shall meet the following requirements as directed in Practice E 317 or other approved procedure:

- (1) Vertical Limit—100 % of full scale.
- (2) Horizontal Limit—100 % of full scale.
- (3) Vertical Linearity Limit Range—The vertical linearity of the instrument shall meet the requirements of A3.3.
- (4) Horizontal Linearity Limit Range—The instrument shall be linear within ± 5 % of full scale between 0 and 85 % of the horizontal limit. This step may be omitted if the instrument is used within a limited depth of material and is verified on standards of that depth at each standardization.

(5) Calibrated gain controls shall meet the requirements of A3.2.2 unless an alternate method for verification has been approved by the cognizant engineering organization.

7.2.1.2 Attenuator and decade switches as applicable shall meet the requirements of A3.2.

7.2.1.3 If automatic means are used for detection of loss-of-back reflection amplitude, it shall be demonstrated that the speed of response of such means is adequate to detect, at actual scanning speeds, at least a -6 dB reduction in back reflection signal from an area no larger than the theoretical area of search unit beam intersection on the near surface of the material. An alternate method such as a near zone FBH with only the back wall gated may be used if approved by the Level III of the cognizant engineering organization.

NOTE 3—This shall be demonstrated by one of the following techniques or a technique approved by the Level III of the cognizant engineering organization.

(1) Place on the surface of the material a temporary spot, consisting of a double layer of masking tape, or other absorptive material, nominally equal to the area of the beam intersection on the near surface. The spot shall be passed through the search unit beam at full scanning speed. When this is done the means used for loss-of-back signal shall indicate at least 50 % reduction in back signal amplitude.

(2) An alternate method is to use a near zone FBH with only the back wall gated.

7.2.2 *Alarm*—An instrument used for other than manual scanning of a part with constant visual observation of the instrument display shall contain a means for automatically indicating the presence of a signal that exceeds a predetermined amplitude threshold within a gated time period. The alarm threshold level shall be adjustable. The alarm means may be an amplitude, visual, stop-on-defect, part marking or sorting, analog or digital recording, or other form of indication of the presence of potential defects. If automatic means are used for detection of rejectable discontinuities, it shall be demonstrated during initial standardization that the speed of response of such means is adequate to detect, at actual scanning speeds, a rejectable amplitude from a target at any depth in the examination range.

7.2.3 *Voltage Regulator*—If fluctuations in line voltage cause an amplitude change greater than ± 2.5 % of full scale of a signal of half full-scale amplitude, a voltage regulator shall be required on the power source.

7.2.4 *Search Units*—Search units are acceptable if they provide the required examination characteristics including sensitivity, resolution, and penetration. Search units shall have active dimensions (diameter for circular elements, length for rectangular elements) equal to or greater than 0.25 in. [6.35 mm]. For contact examination of all convex surfaces of 1.5 in. [38.1 mm] radius or less, and all concave surfaces of 4 in. [101.6 mm] radius or less, a curved shoe or wedge, made to match as closely as possible the radius of the part to be examined, shall be required for examination. All search units shall be serialized. General search unit characteristics are typically evaluated by the methods described in Guide E 1065. Such evaluation does not necessarily determine suitability for any specific material evaluation.

7.2.5 *Rectangular “Paintbrush” Search Units*—Rectangular “paintbrush” search units shall be allowed for straight beam longitudinal immersion scanning if it is demonstrated that the search unit provides the required examination characteristics specified in this practice or the contract document. The written procedures (see 6.4) shall include at least the additional items specified in 7.2.5.1 through 7.2.5.3.

7.2.5.1 A method shall be established for determining that the sensitivity profile along the major axis of the search unit does not vary more than ± 10 % of the vertical limit when the sensitivity is adjusted to provide a nominal 50 % response from a reference reflector (either a steel ball, wire, or flat-bottom hole) as shown in Fig. 1. The profile shall have been verified within a period not exceeding twelve months prior to the date of use of the search unit, unless masking is used to suppress the

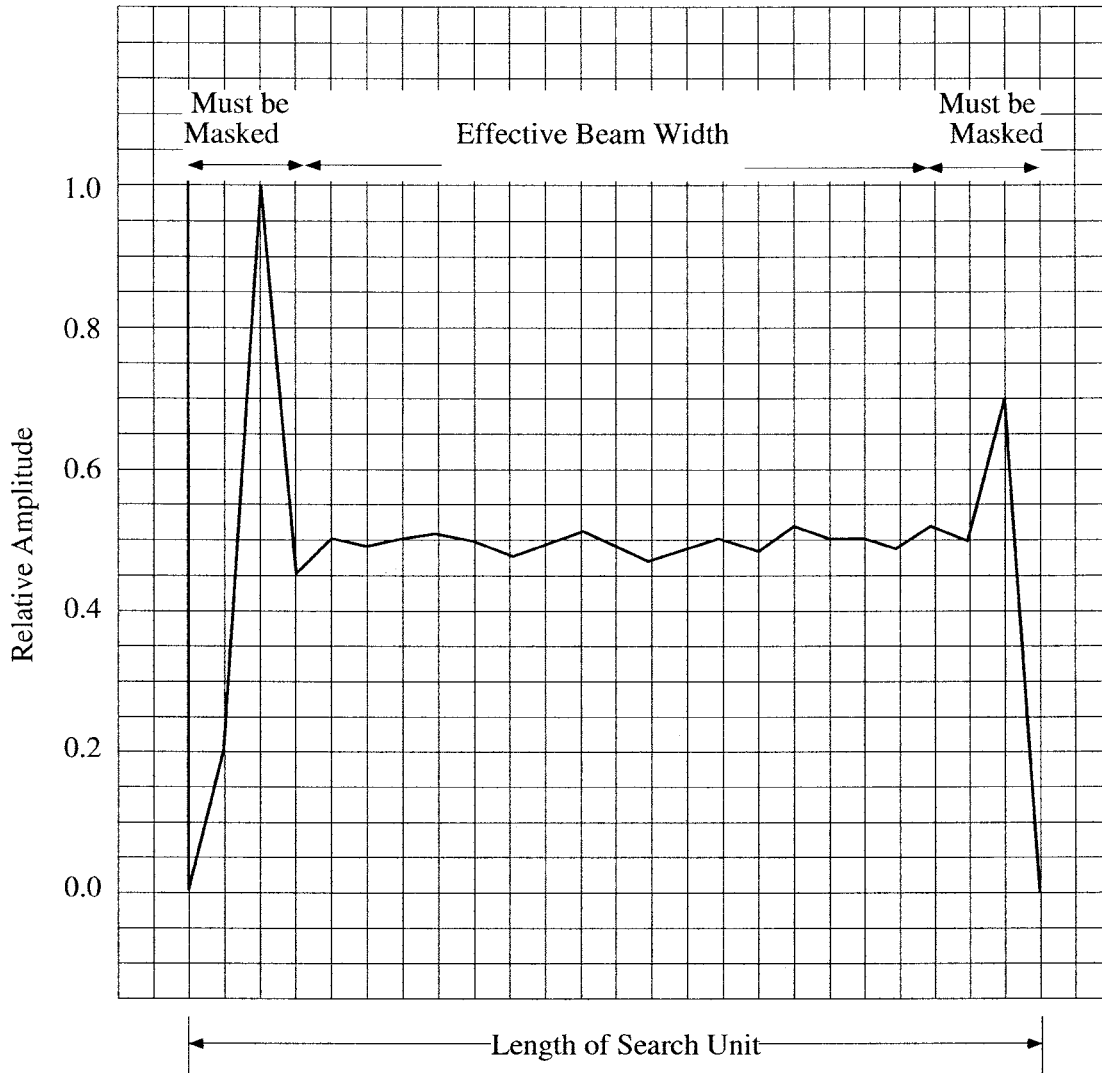

FIG. 1 Acceptable Sound Beam Profile of "Paintbrush" Search Unit

peaks. If masking is used, the search unit profile shall have been verified within a period not exceeding three months prior to the date of use.

7.2.5.2 A method shall be established for masking the ends of the search unit, if required, to eliminate over-sensitive responses as determined in the sensitivity profile, see A4.1.3.

7.2.5.3 A method shall be established for determining effective beam width. The scan index established in accordance with 7.4.10.8 shall be based on the beam width so determined.

7.2.5.4 The reference standard shall provide a uniform entry surface for the full extent of the sound beam for equipment standardization.

7.2.5.5 A method shall be established to use the least active portion of the search unit to adjust scan sensitivity at each portion of the DAC (Distance Amplitude Correction) curve to be used.

7.2.5.6 Search units meeting the requirements of 7.2.4 shall be used for evaluations of indications detected while scanning with paintbrush search units.

7.2.6 *Array Search Units*—Array search units (multiple-element) may be used for initial immersion scanning provided each element is pulsed independently and produces a beam that sufficiently overlaps each adjacent beam so that the maximum allowable drop in signal amplitude between elements is not more than 3 dB from the peak response (when the peak is set to 80 % of full scale using the primary reference response for the applicable examination as the reference reflector). Variations from these requirements are acceptable for phased array search units.

7.2.7 *Focused Search Units*—Focused search units may be used unless otherwise specified in the contract or purchase order documentation.

7.2.8 *Tank*—Tanks used for immersion examination shall be of sufficient size to permit submersion of the part, material, or the area of interest to be examined with proper orientation of the search unit and allow sufficient water path.

7.2.8.1 *Attachments*—For special applications attachments may be used with the search unit to provide the required water path distances or coupling, see 3.2.8.

7.2.9 *Manipulating Equipment*—For immersion examination, manipulating equipment shall adequately support a search unit and shall provide angular adjustment within one degree in two planes and demonstrate control for following part geometry. Examinations not requiring angulation shall be documented on the scan plan. The bridge shall have sufficient strength to provide rigid support for the manipulator and shall allow smooth, accurate positioning of the search unit. The scanning accuracy of the apparatus shall permit adjustment of the scan index distance within ± 0.1 in. [2.54 mm], or unless otherwise specified by the cognizant engineering organization. Water travel distance shall be adjustable. When part size, or configuration, or both, prevent the use of manipulating equipment, search unit stand-off attachments which provide for control of water travel distance and sound beam angle shall be used. Provisions shall be made to ascertain that wear of stand-off attachments does not exceed limits which will degrade the examination.

7.3 *Reference Block Fabrication*—Reference blocks with flat-bottom holes with diameters equal to those specified in the acceptance criteria shall be used for defect detection and evaluation unless alternate hole sizes are used in accordance with 7.3.2. The blocks shall meet the response characteristics of and be certified to the requirements of Practice E 127, E 428, E 1158, as specified in 7.3.1 through 7.3.9.6 of this practice, or to the documented requirements of the cognizant engineering organization. IIW-type blocks shall be certified with respect to alloy and dimensions specified on the purchase order.

7.3.1 *Reference Block Materials*—Reference blocks should be fabricated from the same alloy, surface finish and heat treatment as the part to be examined. Where this is not available, or practical, reference blocks may be fabricated from materials listed in Table 2 so that any ultrasonic transmission differences are minimized. Other material may be used for working reference blocks provided the velocity and attenuation

difference between the reference block and the examination material are within the limits shown below:

7.3.1.1 The longitudinal wave velocity of the material for a reference standard for straight beam (normalized longitudinal wave) shall be within $\pm 10\%$ of the velocity of the examination material. Material for reference standards to be used for angle beam examination shall have a velocity, in the propagation mode to be employed, that is within $\pm 5\%$ of that of the examination material. This may be determined by comparing the sweep distance, on the ultrasonic instrument display, of back or end reflections from equal thicknesses of reference block and examination material.

7.3.1.2 The back or end surface reflections of the examination material shall be within +4 dB (160%) to -12 dB (25%) of the reference block material corrected to the depth of examination. Transfer per 7.4.10.4 is not allowed if the differences are greater than these limits unless a documented plan adequately compensates for the cause and is approved by the cognizant engineering organization.

7.3.1.3 Material to be used for the fabrication of reference blocks shall be scanned ultrasonically in the mode(s) to be used in the examination at a sufficiently high sensitivity to detect any existing anomalies that might produce signals that could obscure, or be confused with, those from holes, notches or other targets in the reference block to be fabricated.

7.3.2 *Alternate Flat-bottom Hole Sizes*—If blocks with the specified flat-bottom hole sizes are not available, alternative sizes may be used provided the instrument gain is changed by a factor given by the ratio of the areas of the two relevant holes. For cases where only a larger size is available, the gain must be increased by the ratio $(d_r/d_a)^2$, where d_r and d_a are respectively the diameters of the reference and specified acceptance flat-bottom holes (see Table 5, Note 1). With instruments having gain controls calibrated in dB, the required change is given by $40 \times \log(d_r/d_a)$ dB. Table 5 can be used for the extrapolation of gain between any standard hole sizes in the range of $1/64$ through $3/64$. Gain extrapolation shall be restricted to hole diameters having ratios no greater than 2:1, requiring gain changes no greater than 12 dB.

7.3.3 *Curved Surface Reference Blocks*—Blocks used on cylindrically or irregularly shaped products shall meet the following requirements:

7.3.3.1 *Examination of Cylindrical Parts of Greater Than 4 in. [101.6 mm] Radius*—Reference blocks shall be of material

TABLE 2 Recommended Reference Block Material

Material to be	Reference Material	Typical Specification
Aluminum	7075-T6	ASTM B 221 ASTM B 241 QQ-A225/9
	2024	ASTM B 221 ASTM B 241 QQ-A225/6
Magnesium	ZK60	ASTM B 107
Titanium	T1-6A1-4V annealed	AMS 4928
Low-Alloy Steels (4130, 4340);	4340 annealed	AMS 6484
High-Strength Low-Steels		AMS 6415
(such as NAX, T-300M);		AMS 6409
Straight Carbon and H-11 Tool		

NOTE—Other materials may be used when documented and approved by the cognizant engineering organization.

TABLE 3 Surface Resolution Requirements

Examination Material	Required
Up to 2.50 in. [63.5 mm]	0.25 in. [6.35 mm]
Over 2.50 in. [63.5 mm]	$1/10$ thickness or $1/2$ in. [12.7 mm] whichever is less.
Solid Round Stock	
0.5 to 5.0 in. [12.7 to 127 mm]	0.25 in. [6.35 mm]
Over 5.0 in. [127 mm]	0.38 in.
Aluminum	
Up to 2.0 in. inclusive [50.8 mm]	0.12 in. [3.05 mm]
Over 2.0 to 10.0 in. [50.8 to 254 mm]	0.25 in. [6.35 mm]
Over 10.0 to 15.0 in. [254 to 381 mm]	0.38 in. [9.65 mm]
Over 15.0 in. [381 mm]	0.50 in. [12.7 mm]

NOTE—Unless otherwise specified in a contract document.

TABLE 4 Flat Surface Reference Standard Metal Travel

Depth of Discontinuity, in. [mm]	Reference Standard Metal Travel Distance Tolerance, in. [mm]
Up to ¼ [6.35]	±¼ [1.59]
0.250 [6.35] to 1.0 [25.4]	±⅓ [3.18]
1.0 [25.4] to 3 [76.2]	±¼ [6.35]
3.0 [76.2] to 6 [152.4]	±½ [12.7]
Over 6.0 [152.4]	±10 % of metal travel

specified in 7.3.1 and shall be the stepped type shown in Fig. 2 (with correspondingly larger dimensions) or, of the type specified in 7.3.2 machined to within 10 % of the radius of curvature of the part being examined, or of the alternate type described in 7.3.7 in which case larger holes may be used to clear a holding fixture for the flat-bottom hole drill as described in 7.3.3.2.

7.3.3.2 Examination of Cylindrical Parts of Less Than 4 in. [101.6 mm] Radius—Reference blocks shall be fabricated from material of the same alloy, heat treatment and surface finish as the part to be examined, and have a radius of curvature within 5 % of those parts. The blocks shall be, where practical, of full round cross-section. Reference holes may be drilled by using a larger diameter hole drilled to no closer than 0.5 in. [12.7 mm] to the final depth of the flat-bottom hole, permitting the use of a holding fixture for the drill for the flat-bottom holes. An acceptable alternate to full round blocks is the stepped type shown in Fig. 2. Flat-bottom holes, of the sizes required for the appropriate examination class per Table 1, shall be placed in the block at the metal travel distances specified in 7.4.7.1. The sizes and depths of the flat-bottom holes shall be verified by calibrated measuring instruments and the holes should be plugged to prevent water entry and to create an air interface at the hole bottom. If it is not possible to use the same material for reference blocks, the provisions of 7.3.1 shall apply.

7.3.3.3 Alternate Tolerances for Straight-Beam Examination of Cylindrical Parts—In the case of straight-beam examination only, where detection of indications of the class specified is demonstrated to the satisfaction of the cognizant engineering organization, the use of reference standards with greater departure of radius from that of the test material than that listed above, may be permitted.

NOTE 4—The use of round cross-section blocks allows the dynamic verification of instrument and system standardization. Such dynamic verification may be difficult, or not possible, using stepped blocks.

7.3.4 Rectangular Angle Beam Reference Blocks—Fig. 3 is the configuration for rectangular angle beam blocks using flat-bottom holes for use with contact examination only. Side-drilled holes may be used to obtain graphic distance-amplitude curves with sensitivity corrected by using the end-drilled holes of the applicable ultrasonic class size (see A1.3.4). Other block configurations and reflectors may be used if they meet the requirements of 7.3.7 and 7.3.8, or comply with documented requirements approved by the cognizant engineering organization. The vee-path options illustrated in Fig. A1.4 shall not be used to obtain standardization of immersion examinations because of the loss of sound energy at the apex of the vee-paths if the block is immersed.

7.3.5 Hollow Cylindrical Angle Beam Reference Blocks—Reference blocks for shear wave examination of tubing and ring forgings shall have an outer ring diameter that is within ±5 % of the outside diameter of the examination material and the thickness shall be ±10 % of the examination material. The reference block shall contain reference reflector notches per Fig. 4 based on the applicable class of examination per Table 1.

7.3.6 International Institute of Welding (IIW) Type Reference Block—Blocks derived from the International Institute of Welding (IIW), Reference Block, Practice E 164 Annex A, shall be used for evaluation of contact angle beam search units as an aid in determining proper positioning for contact angle beam examination, and to determine beam exit point from the search units and angle of the sound beam. The material from which the blocks are to be made must be specified by the purchaser.

7.3.7 Alternate Reference Blocks—Other reference reflectors, as approved by the cognizant engineering organization may be used.

7.3.8 Alternate Reference Block Fabrication—If other types of reference blocks, reflectors and materials are used as approved by the cognizant engineering organization, material for these blocks shall meet the requirements of 7.3.1 and, where applicable, reference targets shall meet the requirements of 7.3.7.

7.3.9 Additional Fabrication Requirements—The following additional fabrication/verification requirements apply to reference blocks specified herein:

7.3.9.1 Flat-bottom holes shall be dimensionally evaluated in accordance with Practice E 428. As an alternate, the holes may be verified in accordance with Practice E 127.

7.3.9.2 The angular alignment of holes in reference blocks shall have a tolerance of ±30 min and be perpendicular to the beam entry surface or other surface or direction as required or intended by the governing specification.

7.3.9.3 Reference standards shall be clearly identified so that the hole size, depth and material type (refracted angle, if used) are discerned on the block or a drawing of the block. If this data is only on the drawing then the reference standard shall be traceable to its drawing.

7.3.9.4 All reference blocks shall be visually examined prior to each use for signs of surface and sealing-plug damage or deterioration. Any block which exhibits significant rusting, corrosion or surface damage, which may interfere with the examination process, shall be either discarded and replaced, or cleaned and recertified per Practice E 127, E 428, or the original surface finish requirements as appropriate.

7.3.9.5 After all flat-bottom holes are verified, they shall be plugged as specified in Practice E 127 or E 428, to protect the hole from corrosion when that is a potential problem.

7.3.9.6 Reference standards shall be dried, or couplant removed, or both, after use. Reference standards shall be handled and stored in a manner to preclude damage.

7.4 Examination Procedures:

7.4.1 Visual Examination—Prior to ultrasonic examination visually examine the part or material for cleanliness, surface roughness, cracks, burrs, nicks, gouges, raised areas, irregular

TABLE 5 Appropriate dB Gain Changes between Flat-Bottom Hole (FBH) Sizes

Acceptable Flat-Bottom Hole Diameter, 1/64 in. [mm]	Reference Flat-Bottom Hole Diameter, 1/64 in. [mm]							
	1 [0.4]	2 [0.8]	3 [1.2]	4 [1.6]	5 [2.0]	6 [2.4]	7 [2.8]	8 [3.2]
1 [0.4]	0 dB	+12 dB						
2 [0.8]	-12 dB	0 dB	+7 dB	+12 dB				
3 [1.2]		-7 dB	0 dB	+5 dB	+9 dB	+12 dB		
4 [1.6]		-12 dB	-5 dB	0 dB	+4 dB	+7 dB	+10 dB	+12 dB
5 [2.0]			-9 dB	-4 dB	0 dB	+3 dB	+6 dB	+8 dB
6 [2.4]			-12 dB	-7 dB	-3 dB	0 dB	+3 dB	+5 dB
7 [2.8]				-10 dB	-6 dB	-3 dB	0 dB	+2 dB
8 [3.2]				-12 dB	-8 dB	-5 dB	-2 dB	0 dB

NOTE 1—Blank areas contain absolute values of gain changes greater than ±12 dB and are not applicable, see 7.3.1.1.

NOTE 2—Reference FBH diameter refers to the size of the FBH in the reference blocks. Acceptance FBH diameter refers to the extrapolated FBH. Table entries are calculated as follows:

$$40 \log_{10} \left(\frac{\text{reference FBH diameter}}{\text{acceptance FBH diameter}} \right) = \text{dB}$$

NOTE 3—+dB = instrument gain increase; -dB = instrument gain decrease.

NOTE 4—If the dB control has a minimum incremental change of 2 dB and the extrapolation requires an uneven dB change, the dB control shall be adjusted for 1 dB more gain than required. For instance, in this case note the dB control in Note 5 would be increased by +10 dB instead of +9 dB.

NOTE 5—Explanation of Extrapolation: With a reference FBH of 5/64 in. [1.98 mm] and an acceptance FBH of 3/64 in. [1.191 mm], the difference is +9 dB. Since the acceptance FBH is smaller than the reference FBH, the gain must be increased by 9 dB from the reference FBH setting.

NOTE 6—This table assumes a linear relationship between the amplitude of the response of an instrument and the area of a flat-bottom hole target. This assumption is approximately valid only for certain material configurations and combinations of search units and instrument parameters.

machining and tool tears. Any surface anomalies that will impair ultrasonic examination shall be removed prior to examination. If removal is not possible or practical, mark such discrepancies on the part for later analysis during evaluation of ultrasonic indications.

7.4.2 *Coverage*—The sound beam direction required for examination of various wrought shapes shall be in accordance with Figs. 6 and 7. Additional coverage requirements shall be as specified below:

7.4.2.1 When directions of maximum stressing are indicated on contract documents, scanning shall be performed to locate discontinuities that are oriented perpendicular to the specified directions (see 6.1).

7.4.2.2 When entry surface resolution is not sufficient to resolve discontinuities near the part surface, as required by Table 3, while achieving at least a 2:1 or greater signal-to-noise ratio, additional examinations shall be performed from the opposite side, or, different examination zone depths shall be established, or the examination frequency may be changed as long as all other requirements are met. Also, for each examination direction, examinations from opposite sides are required when the maximum metal travel distance is such that the minimum size discontinuity of the applicable class cannot be detected by examination from only one side.

7.4.2.3 When the length of any of the examination dimensions (distance sound beam travels through the material) exceeds 18 in. [457 mm] supplementary examinations may be additionally required to locate discontinuities that are not detectable by straight beam examination. This is based on the

fact that it would be very difficult to detect discontinuities greater than 9 in. [228 mm] in depth for a Class A, or higher, examination. It shall be verified that the side walls do not give erroneous examination results.

7.4.3 *Scanning Speed*—The scanning speed shall not exceed the maximum scanning speed which provides for detection of the reference reflectors in the reference standards used to set up the examination.

7.4.4 *Ultrasonic Frequency*—Standardization and examination shall be performed at the ultrasonic frequency which will provide the penetration and resolution required for valid examination of the production material. Examination performed with transmitting and receiving search units of different frequencies shall be considered to be performed at the frequency of the transmitting search unit for broadband systems. For tuned systems, the operating system frequency is established by either the transmitting or receiving system whichever is tuned.

7.4.5 *Water Travel Path for Immersion Method*—The distance from the face of the search unit to the front surface of a part shall be such that the second front reflection from the examination material does not appear between the first front and first back reflections. This distance (water travel) must be the same within ±0.25 in. [±6.35 mm] for standardization, initial scanning and final evaluation. When possible, examination shall be performed using water paths that result in examinations being performed in the far field of the search unit, or in the depth of field of a focused search unit approved by the cognizant engineering organization. When focused

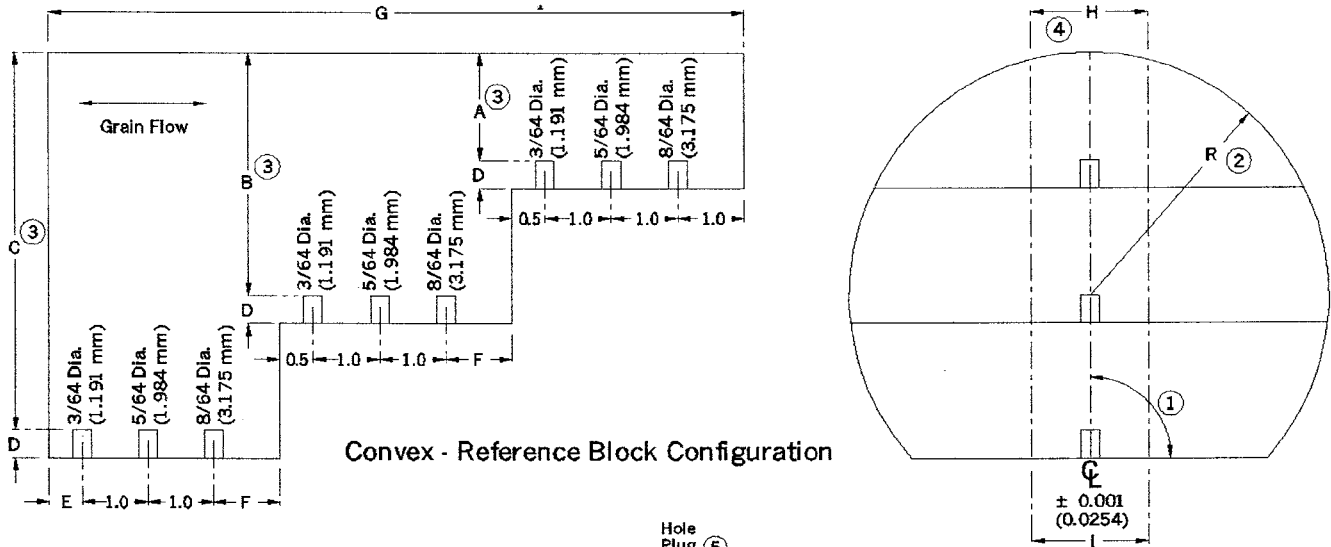

- ① 90° ± 30' Typical
- ② Tolerance: ± 0.025 inch (0.635 mm)
- ③ Tolerance: ± 0.010 inch (0.254 mm)
- ④ 100 R_a Maximum - Top Surface
- ⑤ Plug holes per ASTM E 428

R	A	B	C	D	E	F	G	H
4.0 (101.6)	2.0 (50.8)	4.0 (101.6)	6.0 (152.4)	0.425 (10.8)	1.5 (38.1)	1.5 (38.1)	12.5 (317.5)	2.0 (50.8)
3.5 (88.9)	1.75 (44.5)	3.5 (88.9)	5.25 (133.4)	0.425 (10.8)	1.5 (38.1)	1.5 (38.1)	12.5 (317.5)	2.0 (50.8)
3.0 (76.2)	1.5 (38.1)	3.0 (76.2)	4.5 (114.3)	0.425 (10.8)	1.0 (25.4)	1.5 (38.1)	12.0 (304.8)	2.0 (50.8)
2.5 (63.5)	1.25 (31.8)	2.5 (63.5)	3.75 (95.3)	0.425 (10.8)	1.0 (25.4)	1.5 (38.1)	12.0 (304.8)	2.0 (50.8)
2.0 (50.8)	1.0 (25.4)	2.0 (50.8)	3.0 (76.2)	0.425 (10.8)	1.0 (25.4)	1.5 (38.1)	12.0 (304.8)	2.0 (50.8)
1.5 (38.1)	0.75 (19.1)	1.5 (38.1)	2.25 (57.2)	0.425 (10.8)	1.0 (25.4)	1.5 (38.1)	12.0 (304.8)	2.0 (50.8)
1.25 (31.8)	0.625 (15.9)	1.25 (31.8)	1.875 (47.6)	0.425 (10.8)	1.0 (25.4)	1.5 (38.1)	12.0 (304.8)	1.5 (38.1)
1.0 (25.4)	0.5 (12.7)	1.0 (25.4)	1.5 (38.1)	0.425 (10.8)	1.0 (25.4)	1.5 (38.1)	12.0 (304.8)	1.5 (38.1)
0.75 (19.1)	0.375 (9.53)	0.75 (19.1)	1.125 (28.6)	0.3 (7.62)	1.0 (25.4)	1.0 (25.4)	11.0 (279.4)	1.5 (38.1)
0.5 (12.7)	0.25 (6.35)	0.5 (12.7)	0.75 (19.1)	0.2 (5.08)	1.0 (25.4)	1.0 (25.4)	11.0 (279.4)	1.0 (25.4)

NOTE 1—Primary units are inches, [] are millimetres.

NOTE 2—An approved alternate configuration to that of Fig. 2 is to divide and construct each of the ten reference blocks as three separate blocks; one containing the “C” dimensions, one containing the “B” dimensions, and one containing the “A” dimensions. For this alternate construction, all dimensions of Fig. 2 apply except as follows:

- (1) For each C block, the F dimension shall equal the listed E dimension.
- (2) For each B block, the F dimension and the sketched 0.5 in. [12.7 mm] dimension shall be 1.0 in. [25.4 mm].
- (3) For each A block, the sketched 0.5 in. [12.7 mm] dimension shall be 1.0 in. [25.4 mm].
- (4) The I thickness shows an alternate design based on the H dimension.

NOTE 3—Alternate forms and dimensions of reference standards may be used in accordance with 7.3.3 that contain only the flat-bottom hole diameter(s) necessary to meet Table 1 requirements for the specified examination class and which contain metal travel distances to meet 7.4.7.1 and that have radii of curvature to meet 7.3.1.2.

FIG. 2 Typical Convex Reference Block Configuration for Longitudinal Wave Examination

search units are used, the distance shall be such that the search unit focus is within the material at the depth required to meet front surface resolution requirements. For angle beam examination of curved or cylindrical parts the water path distance

must be maintained at a length which does not vary during material examination or between standardization and examination by more than ±0.02 times the radius of curvature of the material.

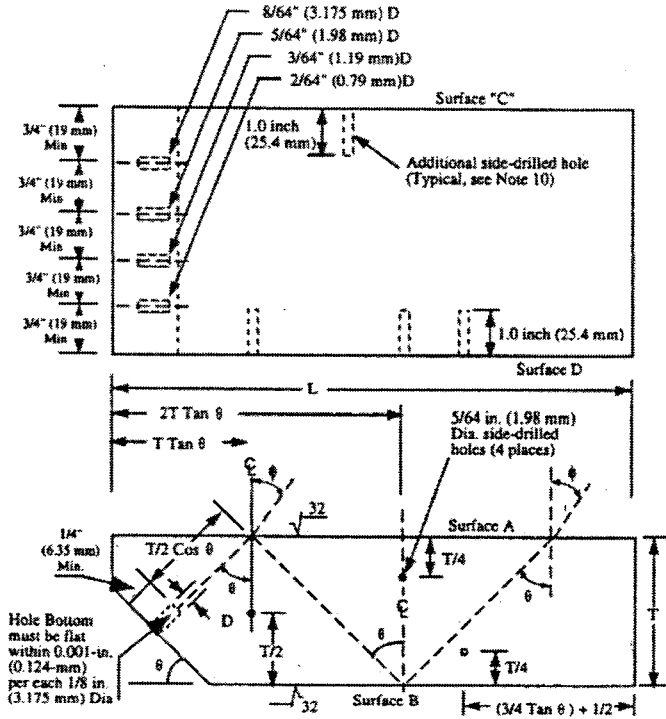

Thickness (t), of Part of Material to be Examined	T	L (Min. Inch)
Up to and Including 1 in. (25.4 mm)	3/4 in. or t (19.05 mm)	(3T Tan θ + 1)
Over 1 in. to 2 in. (25.4 including 50.8 mm)	1-1/2 in. or t (38.1 mm)	↓
Over 2 in. to 4 in. (50.8 including 101.6 mm)	3 in. or t (76.2 mm)	
Over 4 in. to 6 in. (101.6 including 152.4 mm)	5 in. or t (127 mm)	
Over 6 in. (Over 152.4 mm)	t ± 1 in. (25.4 mm)	

All surfaces shall be equal to or smoother than 32 rms or equivalent.

"NOT TO SCALE"

NOTE 1—A block fabricated with flat-bottom holes with diameters as shown will cover all classes in this practice. A narrower block with fewer holes may be used if the block is to be used for a fewer number of classes.

NOTE 2—Side-drilled holes shall not be used for T less than 3/4 in. [19.05 mm].

NOTE 3—A shorter block than shown may be used for thicker materials when only 1/2 or 1 vee-path examining distance is to be used. For shorter reference blocks the side-drilled holes shall be relocated along L so that each hole lies at least 3/4 in. from all sound beam paths used for the other holes.

NOTE 4—D = hole diameter for applicable class.

NOTE 5—θ is the nominal angle of the sound beam in the part with respect to the normal to the sound entry surface. Typical examples: θ = 60° for T = (1/2 in. [12.7 mm] to 1 in. [25.4 mm]) and θ = 45° for T = (Over 1 in.).

NOTE 6—φ is the angle of the entering sound beam with respect to the normal to the sound entry surface.

NOTE 7—Primary dimensions are in inches, metric [XX mm].

NOTE 8—All dimensions ± 0.03 in. [0.762 mm] except for hole diameters which are ± 3 % of diameter specified.

NOTE 9—Surface A and Surface B must be flat and within 0.001 in. per in. [0.025 mm per mm].

NOTE 10—For blocks thicker than one inch, additional 5/64 in. [1.98 mm] diameter side-drilled holes shall be drilled from Surface C with the axes of the holes located 1/4 in. [6.35 mm], 1/2 in. [12.7 mm], 1 in. [25.4 mm], 1-1/2 in. [38.1 mm] and so forth, from surface A until the T/4 distance is reached. No specific location along L is required for these holes except that they shall be located at least 3/4 in. [19.05 mm] from the sound beam paths used for other side-drilled holes.

NOTE 11—All holes should be permanently plugged in a manner to ensure that they are water-tight and that an air-metal interface is preserved.

FIG. 3 Typical Reference Block for Angle Beam Examination

UT Class	Notch Size (Solid Bars)	Notch Size (Tubes)
	Depth ^A × Length, ^B in. [mm]	Depth ^A × Length, ^B in. [mm]
AAA	0.004 [0.10] × 0.188 [4.76]	3 % of Wall ^C × 0.063 ± 0.005 [1.60 ± 0.13]
AA	0.005 [0.13] × 0.250 [6.35]	5 % of Wall ^D × 0.250 [6.35]
A	0.100 [2.54] × 0.500 [12.7]	10 % of Wall ^E × 0.500 [12.7]
B	0.150 [3.81] × 1.000 [25.4]	12.5 % of Wall ^F × 1.000 [25.4]
C	Not Applicable	Not Applicable

^A Depth tolerance = ± 0.0005 in. [± 0.013 mm] for notches 0.005 in. [0.13 mm] or less in depth, and = +10 %, -15 % for notches over 0.005 in. [0.13 mm] depth, except as noted.

^B Length tolerance = ± 0.010 in. [± 0.254 mm] except as noted.

^C 3 % of wall or 0.003 in. [0.076 mm] whichever is greater.

^D 5 % of wall or 0.004 in. [0.102 mm] whichever is greater.

^E 10 % of wall or 0.004 in. [0.102 mm] whichever is greater.

^F 12.5 % of wall or 0.004 in. [0.102 mm] whichever is greater.

NOTE—Notch width to be as small as practical but shall not exceed twice the nominal notch depth.

FIG. 4 Rectangular Notch for Angular Beam Reference Reflectors

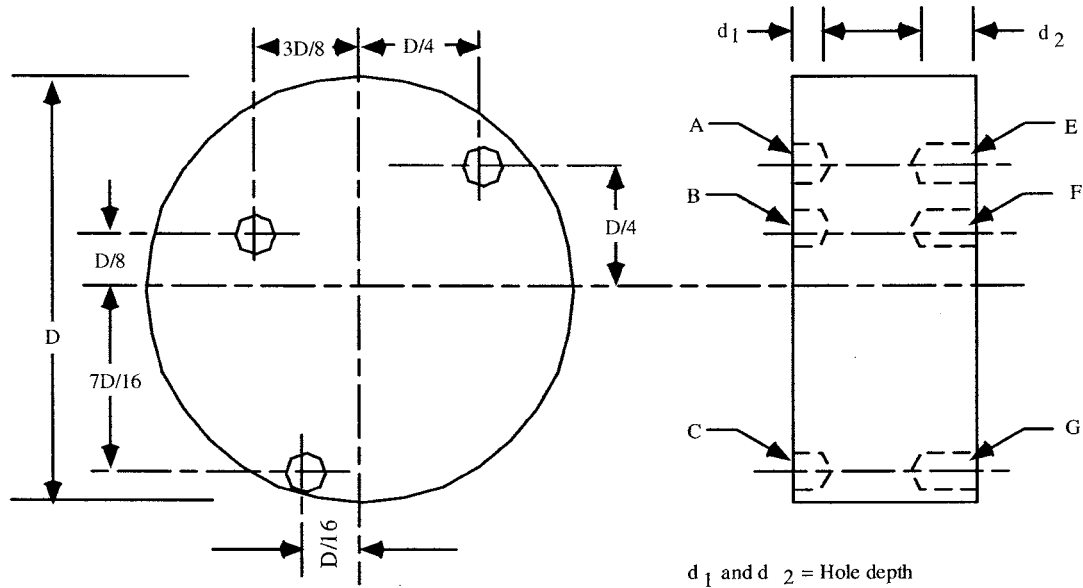

UT Class	Hole Diameter / Depth, in. [mm]	
	Multiple	Single
A	0.020 [0.508] diameter / 0.25 [6.35] depth	0.020 [0.508] diameter / 0.50 [12.70] depth
B	0.020 [0.508] diameter / 0.50 [12.70] depth	0.047 [1.19] diameter / 1.00 [25.4] depth
C	Not Applicable	0.047 [1.19] diameter / 1.00 [25.4] depth

NOTE 1—Tolerance for location of side-drilled holes is ± 0.010 in. [0.254 mm].

NOTE 2—All surfaces Roughness = 125 Ra.

NOTE 3—Multiple and single discontinuity size and spacing requirements are defined in Table 1.

NOTE 4—Since reflections are from the hole side, hole bottoms need not be flat.

Diameter of FBH for which Side-Drilled Hole is to be Substituted, in. [mm]	Side-Drilled Hole (A, B, C, E, F, and G)	
	Diameter ± 0.001 in. [± 0.025 mm]	Depth ± 0.020 in. [± 0.503 mm]
$3/64$ [1.190]	0.020 [0.508]	0.25 [6.35]
$5/64$ [1.980]	0.020 [0.508]	0.50 [12.7]
$9/64$ [3.175]	0.047 [1.190]	1.00 [25.4]

NOTE 5—Side-drilled holes may be used when specified, but are not necessarily equivalent. Holes should be plugged to keep out dirt and water.

FIG. 5 Side-Drilled-Hole Reference Block

7.4.6 Lateral Position Stability for Examination of Cylindrical Parts—During dynamic scanning, variation in position of the vertical centerline of a flat or focused search unit beam with respect to a radius perpendicular to that centerline shall not exceed ± 0.02 times the radius of curvature.

7.4.7 Reference Blocks—Select reference blocks that have been prepared in accordance with 7.3 with flat-bottom-hole (FBH) diameters or reference reflectors for the applicable class (Table 1). Diameters other than specified may be used provided the diameters are within a factor of two and, after the response from the reflector is set to be not less than 80 % FSD, or other amplitude approved by the cognizant engineering organization, and the gain is adjusted by an amount equal to the ratio of the areas of the two reflectors. The examination shall be performed at the equivalent gain level for the specified hole.

7.4.7.1 Reference Block Metal Path Increments—Select reference block(s) containing at least three of the following metal paths distances, unless an alternate plan demonstrates, and is approved by the cognizant engineering organization, that only the extremes of the examination depth of interest are necessary:

(1) A metal path equal to or less than the front surface resolution. When examination is performed from both surfaces of a part, or if solid cylindricals are rotated during examination, examination of only the center-to-far-wall region of the part may be used if defect detection is demonstrated.

(2) A metal path equal to half of the examination piece or zone thickness ± 0.125 in. [3.2 mm].

(3) A metal path equal to or greater than the thickness of the part or zone to be examined.

(4) When examining parts greater than 2 in. [50.8 mm] thickness or diameter, reference reflectors shall be provided with metal paths throughout the examination zone at intervals sufficient to establish total gain requirements and amplitude interpolation.

7.4.8 Preparation for Standardization:

7.4.8.1 Immersion—Using the reference blocks selected per 7.3, immerse the reference standards and search unit in the water bath. Normalize the search unit to maximize the reflected signal from the water-metal interface by manipulating the search unit.

Plate and Flat Bar

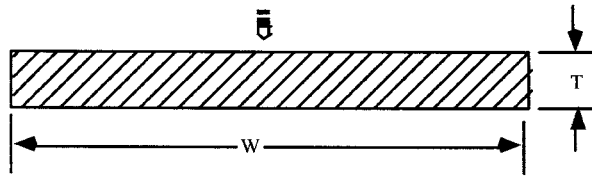

Cross Section
T = Thickness
W = Width

Notes:

1. If $W/T > 5$, scan with a straight beam with the beam directed as shown
2. If W or $T > 9$ inches (228.6 mm), surface resolution requirements may require scanning from opposite side.

Rectangular Bar, Bloom, and Billets

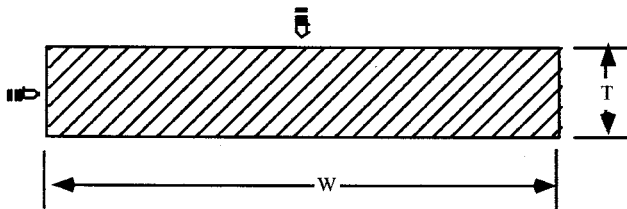

Cross Section
T = Thickness
W = Width

Notes:

1. If $W/T < 5$, scan with a straight beam from two adjacent sides with the sound beam directed as shown
2. If T or $W > 9$ inches (228.6 mm), surface resolution requirements may require scanning from opposite sides.

Round Bars and Round Forging Stock

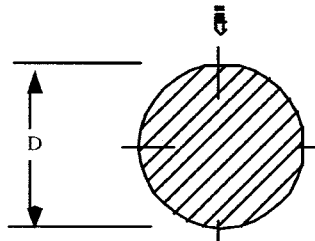

Cross Section
D = Diameter

Notes:

1. Examine by straight beam with sound beam directed towards the center of the bar as shown while bar is rotating to locate discontinuities at or near the center of the bar.
2. When specified in the contract documents purchase order, or engineering drawing scan with a circumferential angle beam technique per appendix A

FIG. 6 Sound Beam Direction for Various Shapes

7.4.8.2 *Contact*—Using the reference standards selected in 7.3, apply the couplant selected per 7.1.2.

7.4.9 *Use of Reference Curve and Direct Comparison Methods for Standardization*—Standardization of the examination shall be accomplished by determining the distance-amplitude relationship for the reference blocks selected in 7.4.7. Compensation for the variation of detection sensitivity with distance from the entry surface shall be accomplished by using either the reference curve method of 7.4.9.1, the direct comparison

method of 7.4.9.2, or electronic distance-amplitude correction (EDAC) as described in 7.4.10.2 and 7.4.10.3.

7.4.9.1 *Reference Curve Method*—Position the search unit on each reference block and maximize the signal amplitude. Set the instrument to achieve the required resolution (for example, pulse length and tuning). Select the reference standard that provides the largest amplitude and adjust the gain to obtain an indication that is not less than 80 % FSD or other approved amplitude. Mark the amplitude of the maximized

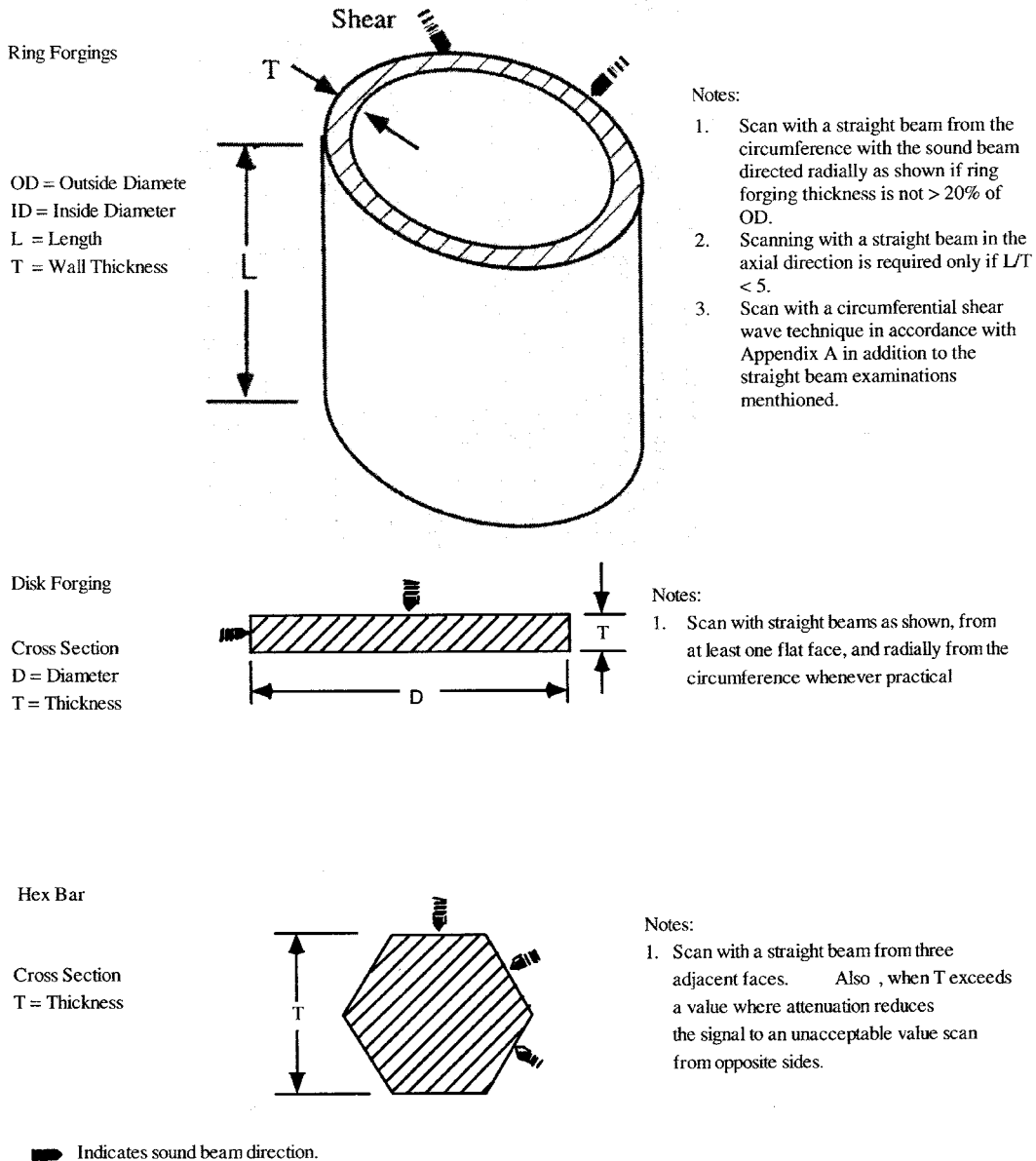

FIG. 7 Sound Beam Direction for Various Shapes

indication from each reference standard on the display and connect the points with a smooth curve. When material thickness and attenuation do not permit the above, zoning and multiple curves or examination from the opposite side may be required. Once this is done, display time based controls (for example, sweep delay and length) shall not be changed.

7.4.9.2 *Direct Comparison Method*—Use block(s) with the proper hole sizes at sufficient metal travel depth to establish the gain relation of the beam profile throughout the full examination depth.

7.4.10 *Establishment of Scanning Gain, Index, and Alarm Level for Standardization*—Determine the gain setting for initial scanning with or without electronic distance-amplitude correction (EDAC). For the applicable class, the multiple discontinuity hole size of Table 1 shall be used to establish the

scanning gain, index, and alarm level, except for Class C, where the single discontinuity hole size shall be used.

7.4.10.1 *Scanning Gain without EDAC*—Set the initial scanning gain by selecting the reference standard that provides the lowest echo amplitude on the distance-amplitude curve as determined by either method of 7.4.9. Maximize the amplitude from the reference reflector in this reference block, and adjust the instrument gain to obtain an amplitude not less than 80 %, or other approved amount, of the upper linearity limit. If required, adjust the gain as determined by the transfer technique, 7.4.10.4. This gain setting is the initial scanning gain level.

7.4.10.2 *Scanning Gain with EDAC*—For systems that employ time-varying gain amplifiers, adjust the gain compensation control so that the indication amplitudes of the reference

reflectors in all reference blocks selected per 7.4.7 are equalized so that the lowest amplitude is not less than 80 % or other approved amount of the upper linearity limit. If required, add any gain determined by the transfer technique (see 7.4.10.4). This is the initial scanning gain level. For systems that employ time-varying trigger level controls, select the reference block with a metal path to the reference reflector that provides the highest echo amplitude on the distance-amplitude curve as determined in 7.4.9. Maximize the amplitude from the reference reflector in this block, and adjust the instrument gain to obtain an amplitude equal to 80 % of the upper linearity limit. If required, add any gain determined by the transfer technique. This is the initial scanning gain level.

7.4.10.3 Electronic Distance-Amplitude Correction (EDAC)—When using EDAC, the reject control shall be off and the responses from the reference standard reflectors at metal distances throughout the range corresponding to part thickness shall be equalized in so far as possible. The lowest response from any of these reflectors, after DAC correction, shall be set to be not less than 80 % FSD or other approved amplitude. Reproducibility shall be verified as specified in 7.5.1.

7.4.10.4 Transfer Technique—The transfer technique shall be used to compensate for differences in sound transmission characteristics that may exist between the reference standards and each part or piece of material to be examined. The transfer technique may be omitted, when approved by the cognizant engineering organization, if not applicable or if another compensation method is more appropriate. Transfer shall be accomplished by noting the dB or gain difference in the responses received from reflectors in the reference block and the part or piece of material to be examined. These reflectors may be the back surfaces for straight beam examinations, corners for angle beam examinations, or any other reflectors which will aid in accomplishing transfer. If possible, a minimum of four reflections from different locations in the part or piece of material to be examined shall be noted and the lowest response shall be used for comparison with the response from the reference standard. The instrument response shall be corrected by first standardizing on the applicable reference blocks and then changing the gain or dB of the instrument by the difference in gain or dB noted above.

(1) **Material Thickness**—The thickness of the specimen (parallel to the ultrasonic beam) shall be measured such that at least two back surface reflections can be resolved at the frequency of interest. The area normal to the ultrasonic beam shall have sufficient width so that sidewall echoes do not interfere with the measurement.

(2) **Exception**—The use of the transfer technique is not required for establishing scanning sensitivity if the signal amplitude from a reflector in each part of each piece of examination material is in the range between 60 and 160 % of the signal amplitude from an equivalent reflector in the reference standard, for example:

$$0.6A_1 \leq A_2 \leq 1.6A_1$$

or, in decibels,

$$-4 \leq 20 \log(A_2/A_1) \leq 4$$

where:

- A_1 = amplitude of the first reflection from a reflector in reference block material, and
- A_2 = amplitude of the first reflection from an equivalent reflector in the material being examined.

7.4.10.5 Resolution—After scanning gain is established per 7.4.10, and if the examination zone includes the front entry surface, ascertain that the required front surface resolution, as listed in Table 3, is obtained.

7.4.10.6 Alarm—When examining parts or material with regular shape and parallel surfaces such as plate, bar stock and forged billets, an audible alarm, stop-on-discontinuity, recorder, or other form of alarm shall be used in conjunction with visual monitoring of the ultrasonic instrument display. If the examination is computer controlled with result print-out, or if the results are otherwise automatically recorded, visual monitoring is not required. When recordings are made, or when systems stop on discontinuities, the audible alarm is not required. Triggering of the alarm shall be controlled by received ultrasonic signals over an adjustable time interval representing the examination zone.

7.4.10.7 Alarm Level Setting—For examination methods as in 7.4.11.1 and 7.4.11.2, adjust the alarm to trigger at 50 % of the standardization level. This corresponds to one half of the indication amplitude of the lowest point on the distance-amplitude curve, or the smallest response if the direct comparison method is used.

7.4.10.8 Scanning Index Determination—Using the reference blocks selected in 7.4.7, and the search unit as required by 7.2.4 through 7.2.6, as applicable, determine the maximum scan index as follows. Maximize the echo amplitude from the primary reference response and adjust the amplitude so that it is equal to that used for standardization. Determine the total traversing distance in the index direction across this reference block through which no less than half (–6 dB) of the maximum amplitude is obtained. This is the effective beam width. Select the block in which the minimum effective beam width of the search unit is obtained. The scan index shall not exceed an amount that, under any random beam-to-reference reflector alignment, will allow the signal from that reference to vary by more than the 2:1 reject-to-alarm level ratio as specified in 7.4.10.7. (For FBH detection this may be accomplished, as a minimum, by not allowing the scan index to exceed 80 % of the –6 dB minimum effective beam width of the search unit at any depth in the examination material.)

7.4.11 Scanning—Scan the part in accordance with 7.4.12 at a speed selected in accordance with 7.4.3.

7.4.11.1 Discontinuities—Note and evaluate in accordance with 7.4.12 all indications that produce signal amplitudes equal to or greater than the alarm level at the scanning gain determined in 7.4.10 after ascertaining that the signals are not produced by surface conditions or geometry.

7.4.11.2 Back Reflection Monitoring—When required, for straight beam examinations, where geometry permits, the back reflection signal or back reflection pattern shall be evaluated at a sensitivity such that this signal, as received from normal, sound material on the same or like part is at an amplitude of between 80 and 90 % of the vertical linearity limit. Any drop

in back reflection signal level below 50 % of the normal value shall be cause for rejection of the part unless it can be shown that the reduction is due to a non-parallel back surface or back surface roughness. If back surface roughness is found to be the cause, the entire examination item shall be reviewed for conformance to the requirements of 7.4.1.

7.4.12 *Evaluation of Discontinuities*—Discontinuities shall be evaluated at the discontinuity depth by manipulating the search unit to obtain the maximum response and comparing to the applicable reference standard (whose metal distance equals the depth of the discontinuity) and discontinuity level specified. See Table 1.

7.4.12.1 *Evaluation of Multiple Discontinuities*—Discontinuities with maximized indications greater than the multiple discontinuity indication limits in Table 1 are rejectable if their positions of maximum response are closer than specified in Table 1.

7.4.12.2 *Evaluation of Linear Discontinuities*—Discontinuities with maximized indications greater than allowed by the linear discontinuity indication limits in Table 1 are rejectable if their lengths are greater than the corresponding lengths given in the table. Methods for measuring lengths are given in Annex A4.

7.4.13 *Corrosion Protection*—Parts shall not be held in immersion tanks beyond the time required for examination. After completion of ultrasonic examination, all parts shall be dried and coated with a corrosion protective material, as necessary, before they are stacked, nested, or placed in contact with one another in any way.

7.5 *Quality Assurance Provisions:*

7.5.1 *System Performance*—In order to check ultrasonic system performance characteristics, standardization of systems with respect to sensitivity in accordance with 7.4.9 shall be performed prior to and immediately after each examination and after any changes in instrument settings, or instrument modules, and at intervals not to exceed four hours during continuous operation. Standardization time interval may be increased with proven, documented repeatability of the examination equipment. If the sensitivity is found to have decreased more than 10 % between standardization checks, the items examined during the interim shall be re-examined at the correct sensitivity. If the sensitivity is found to have increased by more than 10 % between standardization checks the sensitivity shall be readjusted to the correct value as determined by restandardizing in accordance with the applicable parts of 7.4.9 and 7.4.10. However in this case no reexamination of items shall be required. For the purpose of determining standardization interval, repetitive examinations of identical parts or material can be considered to be continuous operation.

7.5.2 *Data Records*—Data records of all examinations shall be kept on file in accordance with the contract or order. Records shall provide for traceability to the specific part or lot examined and shall include the inspector’s identification and certification level, the date of the examination, and the reason of rejection of any rejectable item.

7.5.3 *Acceptance Classes*—Five ultrasonic classes are defined in Table 1 for governing the acceptability of parts and raw materials. A contract document shall specify the class as

defined in this practice. When a part requires multiple classes, a contract document shall indicate the area, or zone, to which each class is applicable. Any other classes not covered by this practice shall be specified in the contract, or order, or those listed in Practice B 594 so specified for wrought aluminum products.

7.5.4 *Acceptance Criteria for Parts to be Machined*—Discontinuity indications in excess of the specified ultrasonic class may be permitted if it is established that such discontinuities will be removed by subsequent machining or trim operations. In such cases, a record of the ultrasonic examination results shall be provided on a grid map or C-scan showing the location and size of indications by discontinuity grade with respect to a “bench mark” on one corner of the surface from which the material is scanned. A final ultrasonic examination shall be performed after machining to assure complete removal of the discontinuity, unless otherwise specified by the contracting agency.

7.5.5 *Rejection*—Items with indications exceeding the limits of the contract requirements (see 5.1) or the written procedure (see 6.4) as applicable, subject to the provisions of 7.5.4, shall be rejected.

7.6 *Marking:*

7.6.1 *Wrought Metal—Raw Stock*—Each item of raw material which has been ultrasonically examined and found to conform to the requirements of this practice and the acceptance requirements of the contract or order shall be marked with a symbol containing a “U” and class, if applicable. The acceptance stamp shall provide identification of the operator and the examination facility. Marking shall be applied in such a manner and location as to be harmless to the item and to preclude removal, smearing or obliteration by subsequent handling.

7.6.2 *Parts Machined from Wrought Metal*—Parts in process which have been ultrasonically examined and found to be acceptable shall be identified by stamping the accompanying paperwork. When practical, the completed parts or raw materials shall be identified with a final acceptance stamp which indicates that all required operations have been completed and accepted. This stamp shall identify the final acceptance operator and the examination facility.

7.6.3 *Other Identification*—Other means of identification, such as dyeing or tagging, or sign-off of the accompanying paper work, shall be applied when the construction, finish or functional requirements preclude the use of stamping or as specified by the contract.

8. Government Contracts

8.1 *Data Requirements*—The following Data Item Descriptions (DID’s) must be listed, as applicable, on the Contract Data Requirements List (DD Form 1423) when this practice is applied on a contract, in order to obtain the data, except where DoD FAR Supplement 27.475-1 exempts the requirements for a DD Form 1423.

Reference Section	DID Number	DID Title	Suggested Tailoring
5.4 and 6.5.3	DI-MISC-90653	Test Report	Contractor’s Format

8.1.1 The above DID was declared as of this date. The current issue of DoD 5010.12L, Acquisition Management Systems and Data Requirements Control List (AMS DL), must be researched to ensure that only current, cleared DID's are cited on the Form 1423.

ultrasonic examination; ultrasonic technique; ultrasound; wrought metal products; wrought metals

9. Keywords

9.1 angle beam; contact method; immersion ultrasonic; longitudinal wave; nondestructive; straight beam; ultrasonic;

ANNEXES

(Mandatory Information)

A1. ANGLE BEAM EXAMINATION

A1.1 Scope:

A1.1.1 This Annex provides angle beam examination requirements and is a mandatory part of this standard to the extent that it is specified in this standard or in a contract document. This annex applies to both longitudinal and shear wave angle beam examinations. **Warning**—The use of outer surface and inner surface notches and the angle beam examination technique described in this annex represent defects near these surfaces and do not allow verification of coverage for mid-way discontinuities.

A1.2 General Requirements:

A1.2.1 *Beam Angle*—Parts and raw materials may be examined by either contact or immersion techniques utilizing angle beam techniques. During examination, the sound beam angle in the object shall not vary more than $\pm 2^\circ$.

A1.2.2 *Contact Angle Beam Search Units*—The exit point and beam angle of the sound beam shall be established for contact angle beam search units. Search units with beam angles varying more than $\pm 3^\circ$ from the manufacturer's indicated values shall not be used unless the new angle is verified and marked on the search unit. The International Institute of Welding (IIW) type ultrasonic reference block (see 7.3.1.3) or an appropriate substitute may be used to determine the exit point and beam angle of angle beam search units. For contact examination of convex surfaces of 4-in. [101.6-mm] radius or less, and concave surfaces of 4.0-in. [101.6-mm] radius or less, a curved shoe or wedge, made to match as closely as possible the radius of the examination piece, shall be required for examination.

A1.3 Examination Requirements:

A1.3.1 *Ring Forgings*—Angle beam examination of ring forgings shall be performed when specified (see Fig. 7). The ring forgings may be examined by an immersion or contact shear wave technique. The reference standard for ring forgings with an outside to inside diameter (OD/ID) ratio that does not exceed 2.0 to 1 shall contain two longitudinal (axial) notches with one on the inside surface and the other on the outside surface. Use a reference reflector notch per Fig. 4 based on the

applicable examination class of Table 1. The standard shall meet the applicable requirements of 7.3.

A1.3.1.1 *Standardization (For Circumferential Scan)*—Scan until the $\frac{1}{2}$ vee-path notch indication from the inside surface first appears. Place the indication at the farthest position to the left on the display. Scan relative to the inside surface notch until the $\frac{3}{2}$ vee-path indication from this notch reappears along the horizontal trace. Mark these two positions on the face of the instrument display. Scan until the notch indication from the outside surface is produced at maximum amplitude between these two marks. The amplitude of this notch indication shall be marked on the instrument display. When the examination instrument employs distance amplitude controls it is recommended that they be used where possible to equalize these indication amplitudes at a minimum of 50 % of full screen height. If this is not possible, or if the instrument is not equipped with a distance-amplitude correction circuit, a distance-amplitude curve shall be constructed on the display with the lowest point at a minimum of 20 % of full screen height.

A1.3.1.2 *Examination Method*—The examination shall be performed with the sound beam directed in both the clockwise and counterclockwise directions with indexing such that each pass of the search unit overlaps the previous pass by not less than 20 % of the effective beam width of the search unit (7.4.10.8). Reject any forging with an indication greater than or equal to the reference notch indication.

A1.3.2 *Solid Round Bars*—Angle beam examination of solid round bars shall be performed when specified (see Fig. 6). The refraction angle used shall be no greater than 45° (see Fig. A1.1). Reference standards shall meet the requirements of 7.3, using reference reflectors per Fig. 4 or Fig. 5 that are equivalent to the applicable class of examination per Table 1.

A1.3.2.1 *Examination Method*—Ultrasonic instrument settings shall be such that the indication from the reference standard is at least 50 % of, but less than 100 % of full screen height. Indexing shall be such that each pass of the search unit overlaps the previous pass by not less than 20 % of the effective beam width of the search unit (see 7.4.10.8). Reject any bar with an indication greater than or equal to the reference reflector indication.

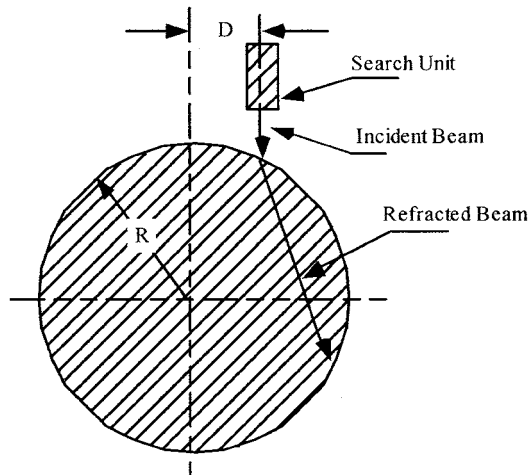

NOTE—The offset distance “D,” from the centerline of the round to the centerline of the search unit, that creates a shear wave no greater than 45° by:

$$D \geq 0.707R (VLW/VSM)$$

where:

- D = offset distance,
- R = radius,
- VLW = velocity of incident longitudinal wave in water, and
- VSM = velocity of refracted wave in metal.

FIG. A1.1 Angle Beam—Round Bar Examination

A1.3.3 *Tubing*—Angle beam examination, when specified, shall be performed as described in Practice E 213 and illustrated in Fig. A1.2. Use an angle beam technique in at least two circumferential directions and preferably also two axial directions to examine the tubing. The reference standard shall contain longitudinal (axial) notches, with one on the outer and one on the inner surface of the standard. If axial scanning is required, the reference standard shall also contain two circumferential notches, again with one on the outer surface and one on the inner surface. The notches shall be in accordance with Fig. 4 based on the applicable class of examination of Table 1. The reference standard shall meet the applicable requirements of 7.3. The longitudinal spacing between the centerline of all notches should not be less than 2 in. [50.8 mm] unless a smaller spacing can be shown to produce no interference when used with the search units to be employed for a specific examination.

A1.3.3.1 *Examination Method*—To standardize for examination adjust the equipment to produce clearly identifiable indications from both the inner and outer surface notches. The response from both notches shall be made as equal as possible. For circumferential scanning this may be accomplished by offset of the search unit (see Fig. A1.2). Use the lesser of the two responses to establish the rejection level. Ultrasonic instrument settings shall be such that this standardization response from the reference standard is at least 50 % of, but less than 100 % of, full screen height. Indexing shall be such that each pass of the search unit overlaps the previous pass by not less than 20 % of the effective beam width of the sound beam (see 7.4.10.8). All indications that are equal to or greater

than the rejection level established during standardization shall be cause for rejection.

A1.3.4 *Flat Surface Angle Beam Examination*—When flat surface angle beam examination is required use the reference Block illustrated in Fig. 3 for both immersion and contact examination.

A1.3.4.1 *Coverage*—Parts may be examined at refracted angles of $45 \pm 5^\circ$ for a section thickness greater than one inch and $60 \pm 5^\circ$ for a section thickness less than one inch.

A1.3.4.2 *Standardization*—Standardization of examination shall be accomplished by determining the distance-amplitude relationship for the examination as follows:

(1) For parts 0.50 to 1.0 in. thick:

(a) Position the search unit to provide sound entry at points one, two, three, and four per Fig. A1.3.

(b) The signal amplitude shall be adjusted to 80% of vertical limit at whichever position gives the highest amplitude signal.

(c) Without changing the gain control, the search unit shall be positioned for maximum response at the other three positions and the signal amplitudes at all positions shall be marked on the screen or transparent overlay. The points shall be joined with a smooth curve. Extrapolation shall be used to extend the curve to the zero metal travel distance position. Fig. A1.3 shows a typical angle beam distance amplitude correction curve.

(d) The search unit shall then be positioned at sound entry point five for maximum response from the applicable size flat-bottom hole, and instrument gain shall be adjusted to bring

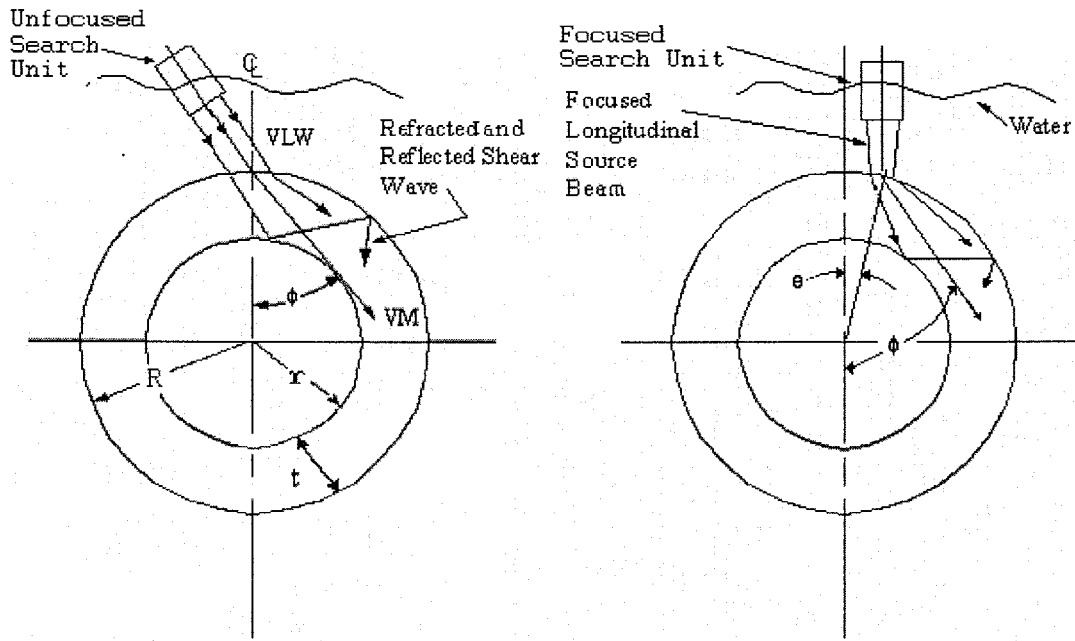

NOTE—Equations for computing Sin θ and d for the respective setup.

$$\sin \theta = \frac{VLW}{VM} \sin \phi$$

$$d = \frac{VLW}{VM} (\sin \phi) R$$

where:

- θ = angle of incident beam
- ϕ = angle of refracted beam
- VLW = velocity of longitudinal waves in water
- VSM = velocity of wave mode in metal (shear or longitudinal)
- d = distance of search unit center line offset from normal to cylinder outer surface

FIG. A1.2 Angle of Incidence and Beam Offset for Circumferential Angle Beam Examination of Hollow Cylinders

the peak of the signal to the distance-amplitude correction curve at points two and five of Fig. A1.3.

(e) If multiple skip distances are to be used, the search unit shall be placed to provide sound entry at point seven and maximum amplitude response from the 1¼ vee path flat-bottom standardization hole shall be marked on the screen. This point shall be used to extend the distance amplitude correction curve.

(f) When the reference standard is thinner than ¾ in. and side-drilled holes are not used, sound entry points five, six, and seven shall be used to establish the distance amplitude correction curve.

(g) Alternatively, EDAC may be used to equalize the responses of DAC position signals at 80 % FSD prior to setting the sensitivity to bring the applicable flat bottom hole response to 80 % of the vertical linearity limit.

(2) Setup technique for parts over 1 in. thick:

(a) Position search unit to provide sound entry at points one, two, three, and four and the additional side-drilled holes per Fig. A1.4.

(b) Distance amplitude correction at metal travel distance between sound entry surface and position one, the ¼ T side-drilled hole, shall be established by reflections from the additional side-drilled holes as shown in Fig. A1.5, Details "A" and "B."

(c) The signal amplitude shall be adjusted to 80 % of vertical limit at whichever position gives the highest amplitude signal.

(d) Without changing the gain control, the search unit shall be positioned for maximum response at the other position and the signal amplitudes at all positions (one, two, three, and four) shall be marked on the screen or transparent overlay. The points shall be joined with a smooth curve. Extrapolation shall be used to extend the curve to the zero metal travel distance position.

(e) The search unit shall then be positioned for maximum response at sound entry point 5 and instrument gain shall be adjusted to bring the peak of the signal to the distance amplitude correction curve at points two and five per Fig. A1.4 presentation.

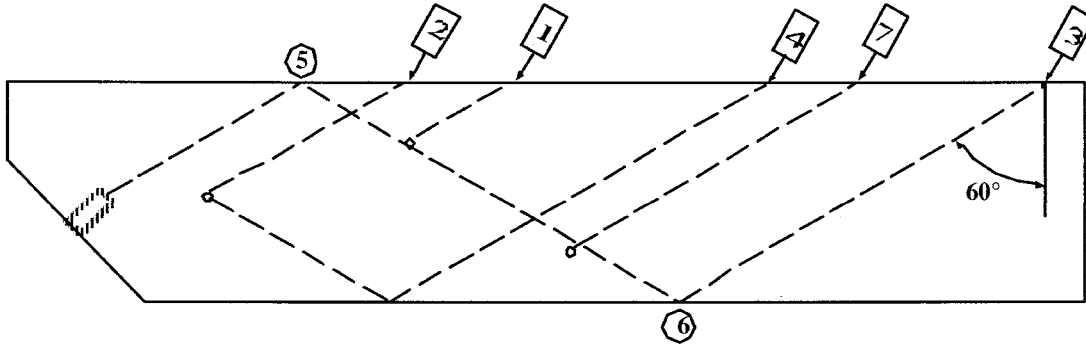

Note: The distance from point 5 to point 6 to point 3 equals one vee-path.

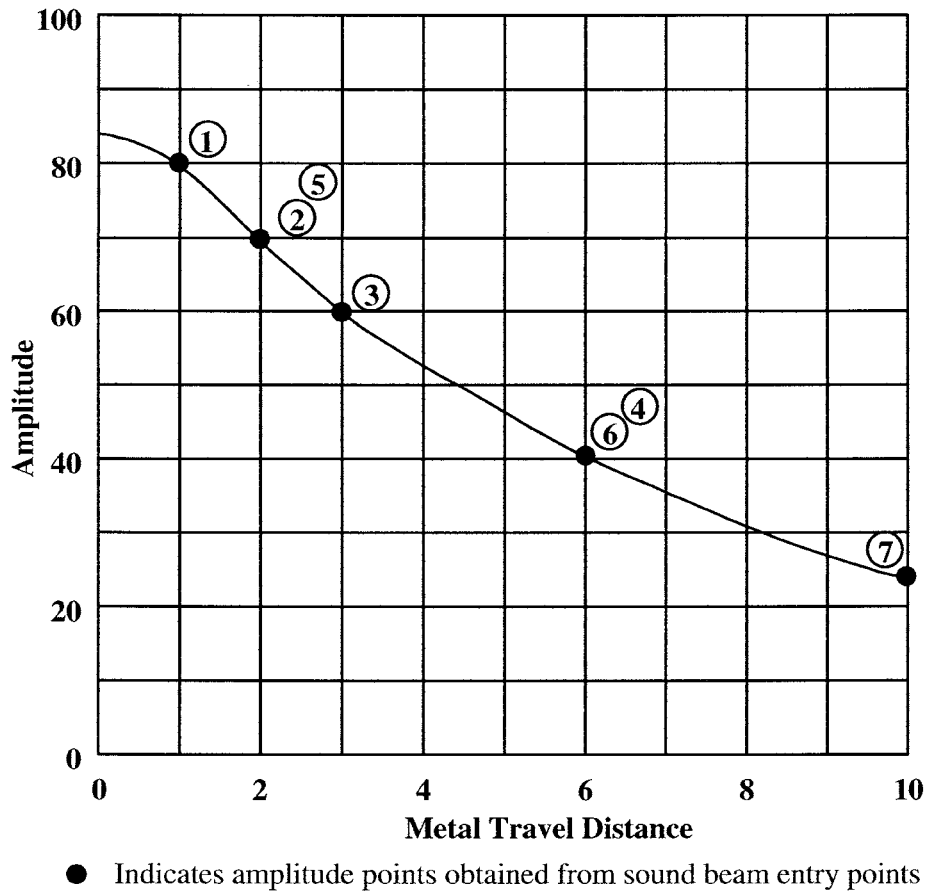
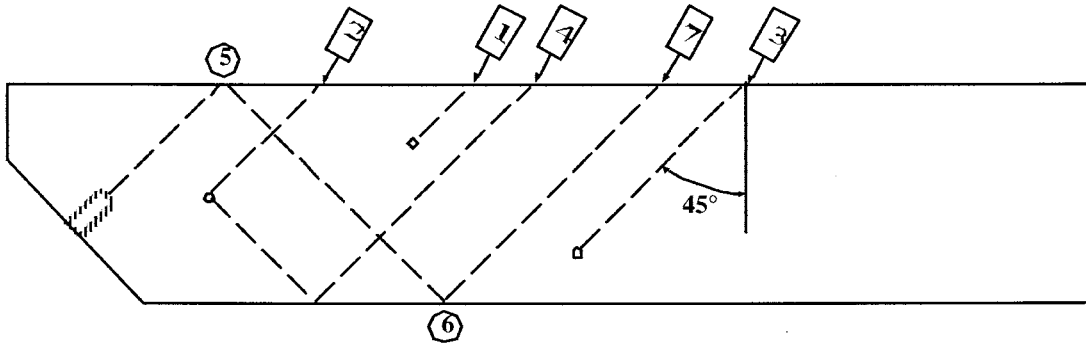

FIG. A1.3 Typical Angle Beam Standardization at 60° for Flat Surfaces of Thin Specimens

(f) If multiple skip distances are to be used, the search unit shall be placed to provide sound entry at point seven and maximum amplitude response from the 1¼ vee path flat-bottom standardization hole shall be marked on the screen. This point shall be used to extend the distance amplitude correction curve.

(g) Alternatively, EDAC may be used to equalize the responses of DAC position signals at 80 % FSD prior to setting the sensitivity to bring the applicable flat bottom hole response to 80 % of the vertical linearity limit.

A1.3.5 Examination Method—Indexing shall be such that each pass of the search unit overlaps the previous pass by not less than 20 % of the effective beam width. Compare the amplitude of the discontinuity indication to the amplitude of the reference reflector indication. Any part or piece of raw material containing a discontinuity from which the amplitude is greater than, or equal to, the reference reflector amplitude shall be marked for rejection.



Note: The distance from point 5 to point 6 to point 7 equals one vee-path.

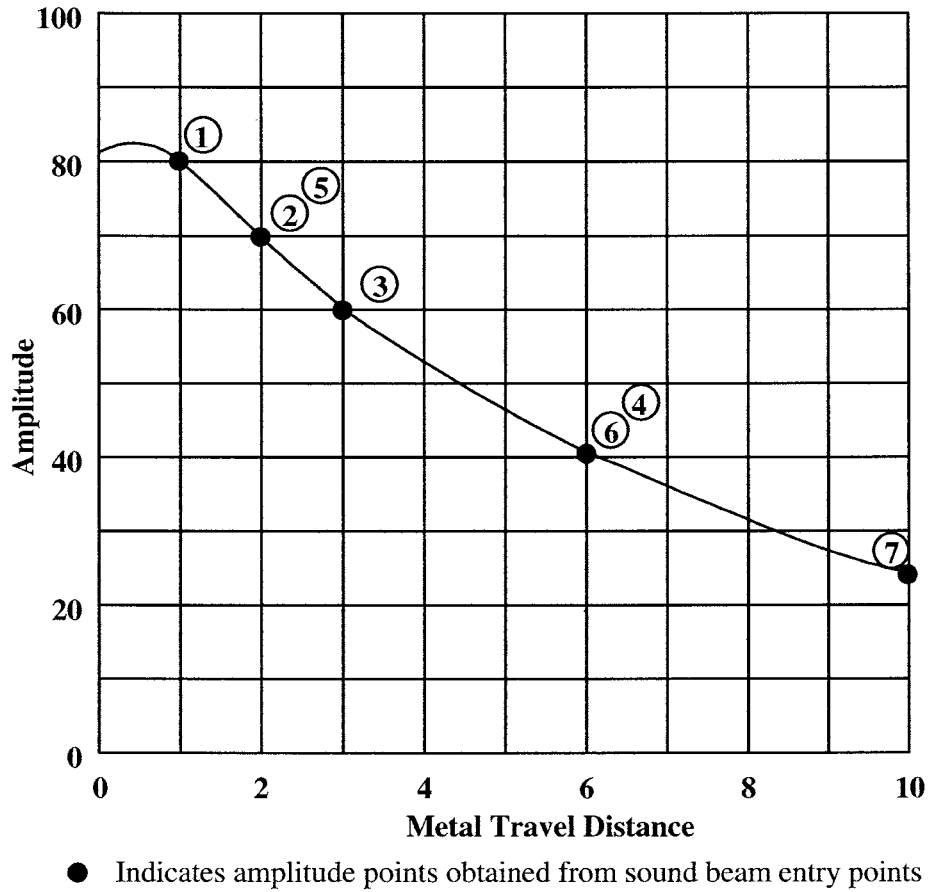
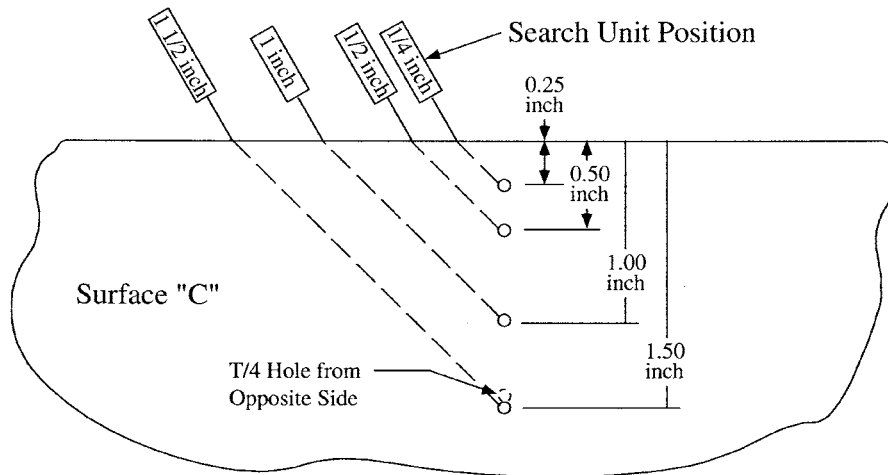
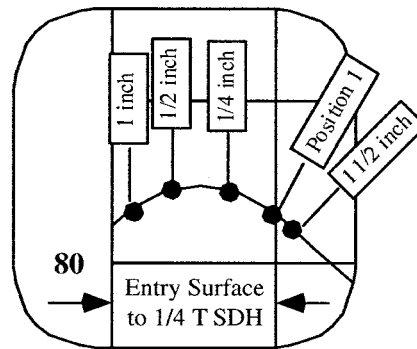

FIG. A1.4 Typical Angle Beam Standardization at 45° for Flat Surfaces of Thick Specimens



Detail "A"
(Viewed from Opposite Side)



Detail "B"

Metric Conversions

<u>inches</u>	<u>mm</u>
1/4 (0.25)	6.35
1/2 (0.50)	12.70
1 (1.0)	25.40
1 1/2 (1.50)	38.10

FIG. A1.5 Angle Beam Standardization for Flat Surfaces of Thick Specimens

A2. EXAMINATION REPORTS TECHNICAL REQUIREMENTS

A2.1 *Scope*—This Annex covers the technical content requirements that shall be included on data records when required by the contract or order. This Annex is mandatory only when data item description DI-MISC-80653 is cited on the DD Form 1423.

A2.2 *Applicable Documents*—This section is not applicable to this Annex.

A2.3 *Reports:*

A2.3.1 *Data Records*—When required by the contract or purchase order the data record shall consist of the following:

A2.3.1.1 The minimum content specified for the written procedure in 7.4.

A2.3.1.2 The information required in 7.5.2.

A3. GAIN CONTROL, ATTENUATOR CALIBRATION, AND LINEARITY CHECK

A3.1 This Annex establishes a procedure and limits for calibrating Gain Controls and Attenuator Switches and for checking linearity. Other methods may be used when approved by the cognizant engineering organization.

A3.2 *Gain Control and Attenuator Calibration*—The following calibrations shall be made at least annually.

A3.2.1 *Controls with linear (Decimal) Calibration*—The following procedure shall be used to establish the accuracy of gain controls and attenuators with linear (Decimal) calibration markings over a range of 100:1.

A3.2.1.1 Switch the instrument for through-transmission examination. Turn the damping, reject and pulse length controls to minimum. Connect a typical straight beam search unit to the “T” (transmitter) connector on the instrument through a coaxial “tee” connector. Connect the input of a calibrated external attenuator to the other leg of the “tee” connector and the output of the attenuator to the “R” (receiver) connector of the instrument, across which also connect a shielded terminating resistor equal in value to the characteristic impedance of the attenuator. (Refer to Practice E 317, Method B, for vertical linearity examination for a further description of these connections.) The voltage rating of the attenuator should be checked against the instrument’s pulser voltage when using a “tee” connector as described. If necessary, a voltage dropping network may be added between the search unit and attenuator.

A3.2.1.2 Set the instrument’s gain, or attenuator controls, or both, to settings that correspond to a sensitivity of between 5 and 10 % of the maximum available from the instrument as indicated by the calibration markings on the controls. With the external attenuator set for 20 dB attenuation, adjust the position of the search unit over the target in any suitable reference block to which the search unit is coupled, and adjust the position of any instrument damping, pulse length, or uncalibrated gain control, or a combination of the three, to obtain a response from the target of between 80 and 95 % FSD. Record this amplitude and the gain control setting. These will be referred to below as the reference gain setting and the reference signal response.

A3.2.1.3 Switch in an additional 6 dB attenuation for a total of 26 dB on the external attenuator. Adjust the instruments calibrated gain, or attenuator controls, or both, to produce a value equal to twice, +6 dB, the initial reference gain setting in A3.2.1.2. Record the new gain setting and the amplitude of the

resultant signal response. It shall be within ± 5 % FSD of the reference signal response obtained in A3.2.1.2.

A3.2.1.4 Switch in an additional 14 dB for a total of 40 dB on the external attenuator. Set the instrument’s calibrated gain / attenuator controls to a value equal to ten times the reference gain setting in A3.2.1.2. Record the new gain setting and the amplitude of the resultant signal response. It shall be within ± 5 % FSD of the reference signal response obtained in A3.2.1.2.

A3.2.1.5 Switch in an additional 6 dB for a total of 46 dB on the external attenuator. Adjust the instrument’s calibrated gain / attenuator controls to a value equal to 20 times the reference gain setting in A3.2.1.2. Record the new gain setting and the amplitude of the resultant signal response. It shall be within ± 5 % FSD of the reference signal response obtained in A3.2.1.2.

A3.2.1.6 Switch in an additional 14 dB for a total of 60 dB on the external attenuator. Adjust the instrument’s calibrated gain / attenuator controls to a value equal to 100 times the reference gain setting in A3.2.1.2. Record the new gain setting and the amplitude of the resultant signal response. It shall be within ± 5 % FSD of the reference signal response obtained in A3.2.1.2.

A3.2.2 *dB Calibrated Gain control and Attenuator Switches (including Smart Knobs, Menu-Guided Parameter Selection, and so forth)*—The following procedure shall be used to establish the accuracy of gain controls and attenuators.

A3.2.2.1 Switch the instrument for through-transmission examination. Turn the damping, reject and pulse length controls to minimum. Connect a typical straight beam search unit to the “T” connector on the instrument through a coaxial “tee” connector. Connect the input of a calibrated external attenuator to the other leg of the “tee” connector and the output of the attenuator to the “R” connector of the instrument, across which also connect a shielded terminating resistor equal in value to the characteristic impedance of the attenuator. (Refer to Practice E 317, Method B for vertical linearity testing for a further description of these connections.)

A3.2.2.2 With the external attenuator set for 20 dB attenuation, set the instrument’s attenuation / gain controls to obtain a minimum value which produces a signal of approximately

90 % FSD from the first back reflection of any suitable reference block to which the search unit is coupled. Record the signal amplitude.

A3.2.2.3 Increase the external attenuator by 2 dB and increase the instrument gain (decrease the attenuation) by 2 dB. Record the resulting signal amplitude. It shall be within ± 5 % FSD of the previous signal.

A3.2.2.4 Repeat A3.2.2.3 as many times as necessary to cover the range of instrument control settings to the point where “noise,” lack of additional gain, or internal signal “feed through” in the instrument renders further external attenuation ineffective. If separate “coarse” and “fine” attenuator controls are provided, the 2 dB increments need be applied only once to check calibration of the “fine” control step settings. Increments equal to the “coarse” control steps shall be used as in A3.2.2.3 to check calibration of the “coarse” control.

A3.2.2.5 If the limits cannot be met at each step, corrective action must be taken, and the attenuator calibration check shall be rerun.

A3.3 *Linearity Check*—The linearity check of a flaw detection instrument from input to display (and from input to recorder output if recording is used as the sole source for indication evaluation) shall be made using a calibrated external attenuator. (Refer to Practice E 317, Method B, for vertical linearity testing for a further description of these connections.) This check shall be made annually (calibration).

A3.3.1 The linearity shall be checked over a range of response amplitude of at least 15 to 90 % FSD in no less than

five steps. The input to the instrument shall be from a search unit coupled to a suitable reference block. The input signal shall be of sufficiently low amplitude as to avoid saturation of early amplifier stages in the instrument. (A high-order back surface multiple may be used for this purpose.) To avoid variable output impedance effects from the external attenuator, its minimum attenuation shall be not less than 20 dB during this check.

A3.3.2 Measured deflections (or recorder output indications) shall be within ± 5 % FSD of the theoretical values for the attenuation steps used with an additional allowance for reading error of up to ± 1 % FSD. Table A3.1 illustrates typical steps which may be used and the resulting acceptance limits when the instrument is adjusted to produce an initial 80 % FSD response with 21 dB external attenuation.

TABLE A3.1 Typical Attenuator Linearity Check Data

External Attenuator (dB)	Theoretical Amplitude (% FSD)	Amplitude Limits	
		+5 % FSD	-5 % FSD
20	89.76	95	84
21	80.00	—	—
22	71.30	77	66
23	63.55	69	58
25	50.48	56	45
27	40.09	46	35
29	31.85	37	26
33	20.10	26	15
37	12.68	18	7

A4. MEASUREMENT OF LENGTH OF LINEAR INDICATION

A4.1 *Scope*:

A4.1.1 *Introduction*—This Annex provides two methods for determining the length of a linear discontinuity. The first method A4.1.2 is less accurate than the second method A4.1.4. The second method accurately measures indications that are shorter than the effective beam width of the search unit at the estimated depth of the discontinuity. Also, this method requires an accurate measurement of the effective beam width at the discontinuity depth, see A4.1.3.

A4.1.2 *Measurement of Discontinuity Length by the “-6 dB Method”*—This method accepts the discontinuity length as equal to the distance that the search tube is displaced along the line of the discontinuity between the points where the signal amplitude has decreased to 50 % of its peak value. That method yields a larger-than-actual length for discontinuities that are shorter than the search unit beam width. Although that error is “safe” in the sense that it will not result in the acceptance of rejectable discontinuities it can lead to the rejection of discontinuities of less-than-rejectable length.

A4.1.3 *Measurement of Total Effective Beam Width of Search Unit*—For this method to yield accurate results it is necessary that the total effective beam width of the search unit

be known at the estimated depth of the discontinuity. This shall be measured by scanning the search unit over the FBH at the depth in the reference standard that is nearest the depth of the discontinuity in the examination material. The effective beam width shall be taken as the distance along the scan line between the points at which the signal from the FBH falls to 10 % of its peak value or into the noise level, whichever is greater. Any other method which can be shown to be capable of measuring the effective total beam width of the search unit at the estimated discontinuity depth in the examination material may be used.

A4.1.4 *Measurement of Discontinuity Length by “-20 dB Method”*—After measurement of the total beam width of the search unit per A4.1.3, or other equivalent method, the search unit shall be scanned along the discontinuity and the distance measured between the points at each end where the signal from the discontinuity is reduced to 10 % of its peak value (-20 dB) or just disappears into the noise level, whichever occurs first. The length of the discontinuity may then be found by subtracting from this distance the measured beam width of the search unit.

ASTM International takes no position respecting the validity of any patent rights asserted in connection with any item mentioned in this standard. Users of this standard are expressly advised that determination of the validity of any such patent rights, and the risk of infringement of such rights, are entirely their own responsibility.

This standard is subject to revision at any time by the responsible technical committee and must be reviewed every five years and if not revised, either reapproved or withdrawn. Your comments are invited either for revision of this standard or for additional standards and should be addressed to ASTM International Headquarters. Your comments will receive careful consideration at a meeting of the responsible technical committee, which you may attend. If you feel that your comments have not received a fair hearing you should make your views known to the ASTM Committee on Standards, at the address shown below.

This standard is copyrighted by ASTM International, 100 Barr Harbor Drive, PO Box C700, West Conshohocken, PA 19428-2959, United States. Individual reprints (single or multiple copies) of this standard may be obtained by contacting ASTM at the above address or at 610-832-9585 (phone), 610-832-9555 (fax), or service@astm.org (e-mail); or through the ASTM website (www.astm.org).